

eKinex

CONTROL YOUR LIVING SPACE



Application manual KNX room temperature controller EK-EQ2-TP

Index

Foreword.....	6
1 General information	6
1.1 Function	6
1.2 Main functional features.....	6
1.3 Technical data	7
1.4 Design	7
1.5 Delivery	8
1.6 Accessories.....	8
1.7 Marks and certification	8
2 Installation.....	9
2.1 Connection.....	9
2.1.1 Connection of the bus line.....	9
2.1.2 Connection of the inputs	9
3 Configuration and commissioning	11
3.1 Configuration.....	11
3.1.1 Tree structure of the application program	11
3.1.2 Languages of the application program.....	12
3.2 Commissioning	13
3.2.1 Displaying physical address and firmware release	13
4 User interface	15
4.1 LCD-display	15
4.1.1 Information displaying	15
4.1.2 Segment test	16
4.1.3 Backlight.....	17
4.2 Rockers	17
5 Sensors.....	18
5.1 Temperature sensor.....	18
5.2 Relative humidity sensor.....	18
6 Input variables	19
7 Application program for ETS	20
7.1 About EK-EQ2-TP.....	20
7.1.1 General.....	21
7.1.2 Parameters.....	21
7.2 Internal sensors	23
7.2.1 Parameters.....	23
7.2.2 Temperature sensor	23
7.2.2.1 Parameters and communication objects.....	23
7.2.3 Relative humidity sensor	25
7.2.3.1 Parameters and communication objects.....	25
7.3 Inputs	27

7.3.1	Input X.....	27
7.3.2	Parameters and communication objects.....	27
7.4	External sensors (from bus).....	31
7.4.1	Parameters and communication objects.....	31
7.5	Weighted temperature value.....	34
7.5.1	Parameters and communication objects.....	34
7.6	LCD-display.....	36
7.6.1	Parameters.....	36
7.7	Leds.....	38
7.7.1	Parameters and communication objects.....	38
7.8	Temperature control.....	40
7.8.1	Settings.....	40
7.8.1.1	Parameters and communication objects.....	40
7.8.1.2	Heating/cooling switchover.....	43
7.8.1.3	Valve protection function.....	44
7.8.1.4	Remote Setpoint modification.....	44
7.8.1.5	Remote operative mode modification.....	45
7.8.2	Heating.....	47
7.8.2.1	Parameters and communication objects.....	47
7.8.3	Cooling.....	52
7.8.3.1	Parameters and communication objects.....	52
7.8.4	Main and auxiliary ventilation.....	57
7.8.4.1	Parameters and communication objects.....	57
7.8.4.2	Delayed fan start ("hot-start") function.....	60
7.8.4.3	Antistratification function.....	60
7.8.4.4	2-stage configuration with fan-coils as auxiliary stage.....	60
7.8.4.5	Remote fan speed modification.....	61
7.8.5	Scenes.....	63
7.8.5.1	Parameters and communication objects.....	63
7.9	Relative humidity control.....	65
7.9.1	Dehumidification.....	65
7.9.1.1	Parameters and communication objects.....	65
7.9.2	Humidification.....	67
7.9.2.1	Parameters and communication objects.....	67
7.10	Comfort.....	68
7.10.1	Comfort area.....	68
7.10.1.1	Parameters and communication objects.....	68
7.10.2	Calculated psychrometric values.....	69
7.10.2.1	Parameters and communication objects.....	69
7.11	Energy saving.....	71

7.11.1	Window contacts	71
7.11.1.1	Parameters and communication objects	71
7.11.2	Presence sensors	72
7.11.2.1	Parameters and communication objects	72
7.11.3	Card holder.....	73
7.11.3.1	Parameters and communication objects	73
7.12	Additional warnings.....	75
7.13	Logic functions	76
7.13.1	Parameters and communication objects.....	76
8	List of communication objects	78
9	Regulation algorithms	81
9.1.1.1	Two-point control with hysteresis	81
9.1.1.2	Continuous Proportional-Integral control	83
9.1.1.3	PWM Proportional-Integral control	84
9.1.1.4	Fan-coil with ON-OFF fan speed control	86
9.1.1.5	Fan-coil with continuous speed control	88
9.1.1.6	2 points control with hysteresis for auxiliary stage.....	90
9.1.1.7	Auxiliary stage with fan-coil.....	90
10	Diagnostics	92
11	Warnings.....	93
12	Other information.....	93

Revision	Updating	Date	Author
4.0	Added offset management for relative humidity (par. 7.2.3). Switching to the ETS 4.0 application.	8/11/2022	G. Schiochet
3.0	ETS application version: VER 3.00. Modified and/or added features: ⇒ Communication object 101 Building protection HVAC mode active ⇒ Communication object 102 Fan manual speed percentage ⇒ Communication object 103 Fan manual speed off status ⇒ Brightness sensor and corresponding functionalities removed	27/06/2017	G. Schiochet
2.0	ETS application version: VER 2.00. Modified and/or added features: ⇒ Heating/cooling status out and Heating/cooling status in communication objects (more enhanced management) ⇒ Communication objects for operating modes' remote control, setpoint temperature and auto/manual mode of fan ⇒ Logic functions AND, OR, EXOR, 4 inputs, 8 channels	20/06/2016	R. Rocco
1.0	Emission	02/04/2015	R. Rocco

The latest revision of the application manual is available at www.ekinex.com. For previous revisions, contact the technical support at support@ekinex.com.

Foreword

The present document describes the ekinex® KNX room temperature controller with LC-display (EK-EQ2-TP version).

1 General information

The device described in the present document works as an electronic digital temperature controller for a room or a zone (consisting e.g. in a group of rooms or a whole floor) of a building and is part of the secondary regulation for heating and cooling. The room temperature controller has been developed according to the KNX standard for use in systems of control of homes and buildings.

Through the integrated sensors, the device can measure directly in the room the temperature and relative humidity values that can be used for control and regulation tasks of heating, cooling and ventilation. Via the bus the device can furthermore receive temperature, relative humidity and CO₂-concentration values from other bus devices. The integrated display visualizes a series of information concerning the room controller function. The device is provided with two rockers that can be used for controlling the thermostat function. The two physical inputs may be configured independently as analogic or digital and allow to extend the basic functions, optimizing comfort, safety and energy savings depending on the user or building needs. The device can furthermore report whether the room or zone is in a thermal comfort field configurable according to the building use, the activities done and other specific factors.

1.1 Function

The main function of the device is to control the temperature of the air mass of the room by means of the actual temperature (T_{eff}), measured by the device itself or received by the bus, and of the setpoint temperature (T_{set}) set by the user; comparing the two values and a series of parameters set before the commissioning, the regulation algorithm of the device calculates the control variable value that is converted to a telegram and transmitted on the bus toward KNX actuators (such as binary outputs, fan-coil controllers, valve drives, etc.) able to control the operation of heating and cooling terminal units.

1.2 Main functional features

The main functions carried out by the device are:

- temperature and relative humidity measuring through the integrated sensors with possibility of sending the values on the bus;
- 2-points (on/off) or proportional (PWM or continuous) room temperature regulation;
- ventilation control with continuous or 3-speed regulation;
- relative humidity control both in humidification and dehumidification;
- seasonal modes: heating and cooling with local or via bus switch-over;
- operating modes: comfort, standby, economy and building protection with separate setpoint values for heating and cooling;
- manual or automatic control of a fan-coil unit with 2-pipes or 4-pipes connection
- automatic switching of the operating mode when presence/absence of people or window opening is detected;
- weighted average of two temperature values;

- temperature displaying (measured, setpoint, perceived and outdoor values in °C or °F), relative humidity (measured and setpoint values in %) and CO₂-concentration (in ‰, received from bus), alarms and errors (with alphanumeric codification);
- signaling opening windows;
- calculation of psychrometric values (dew-point temperature and perceived temperature) with possibility of sending the values on the bus;
- limitation of the surface temperature for floor heating radiant panels;
- anticondensation protection for floor and ceiling cooling radiant panels;
- antistratification function;
- delayed fan start (“hot-start” function) time-scheduled or depending on the conveying fluid temperature measured at the coil battery;
- sending on the bus of the condition internal or external from the area of comfort (configurable).

1.3 Technical data

Feature	Valore
Device	KNX S-mode bus device
Communication	according KNX TP1 standard
Use	dry internal rooms
Environmental conditions	<ul style="list-style-type: none"> • Operating temperature: - 5 ... + 45°C • Storage temperature: - 25 ... + 55°C • Transport temperature: - 25 ... + 70°C • Relative humidity: 95% not condensating
Power supply	SELV 30 Vdc from bus KNX (auxiliary power supply not necessary)
Current consumption from bus	< 13 mA
Elementi di comando	2-fold pushbutton for direct access to 4 funzioni indipendenti mediante pressione breve (< 5 s) e indiretto ad altre funzioni mediante pressione prolungata (> 5 s)
Programming elements	1 pushbutton and 1 LED (red) on the front side
Display elements	1 backlighted LC-display, 8 LED (4 for each rocker)
Temperature sensor	1 integrated NTC-type
R.H. sensor	1 integrated
Accessories	2 square (40x40 mm) rockers and a square frame of the flank or form series (to be ordered separately) - 'NF (No Frame versions) do not require any frame
Installation	On round or square wall-mounting box with distance between fixing holes of 60 mm
Connection	<ul style="list-style-type: none"> • bus: black/red KNX terminal block • inputs: screw terminal blocks
Protection degree	IP20
Dimensions (WxHxD)	82 x 75 x 35 mm

1.4 Design

The device is realised for wall-mounting on round or square wall box with distance between fixing holes of 60 mm. The programming pushbutton and the programming led are on the front side under the rockers. On the rear side of the housing there is the 4-pole terminal block for the connection of the 2 inputs and the terminal block for the connection of the bus.

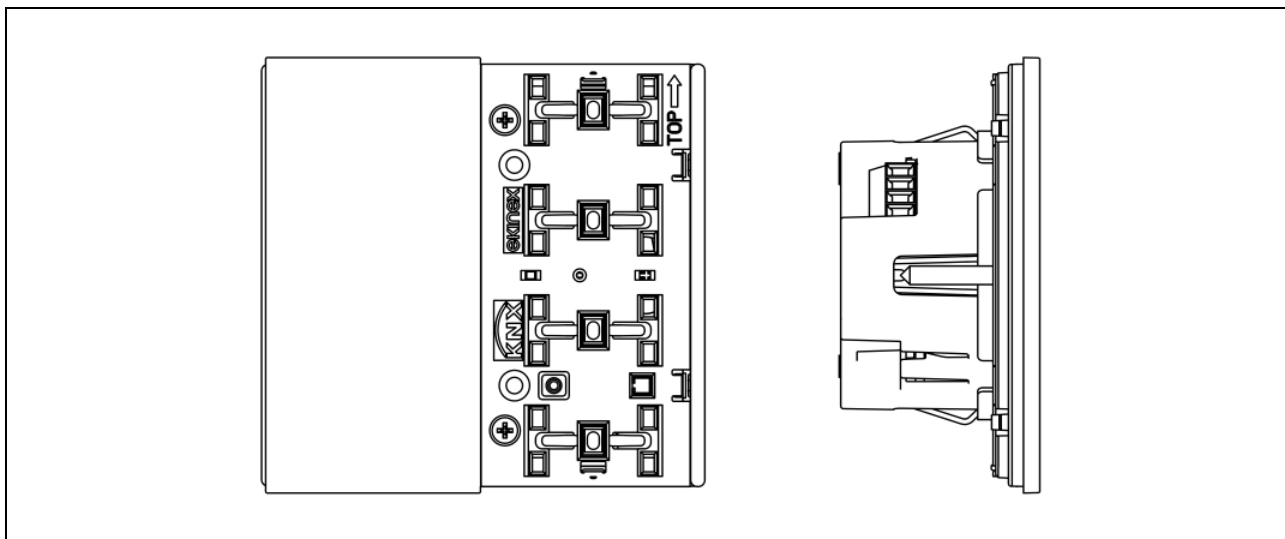

Device: front and side sights

1.5 Delivery

The delivery includes a device, the terminal block for the connection of the bus, the screws (2 pairs) and the metallic support for mounting on the wall box. The packaging includes also the device instructions.

1.6 Accessories

The device is completed with a set of two square 40x40 mm rockers and a square frame of the form (EK-FOQ-...) or flank (EK-FLQ-...) series that have to be ordered separately. The 'NF (No Frame) version does not require any frame (see also the following table). Temperature sensors and other devices to be connected to the inputs must be ordered separately.

Code	Version	LED colours	Device housing	Accessories
EK-EQ2-TP	with frame	blue / green	black plastic	set rockers EK-TSQ-G...-EP2 and square frame of form (EK-FOQ-...) or flank (EK-FLQ-...) series
EK-EQ2-TP-RW		white / red		
EK-EQ2-TP-BG-NF	'NF (without frame)	blue / green	white plastic	set rockers EK-TSQ-G...-EP2
EK-EQ2-TP-RW-NF		white / red		
EK-EQ2-TP-BG-NFW		blue / green		
EK-EQ2-TP-RW-NFW		white / red		

Accessories of the device: set of rockers and frames

1.7 Marks and certification

The KNX mark on the ekinex device ensures interoperability with the KNX devices of Ekinex S.p.A. and other manufacturers installed on the same system bus system. The compliance with the applicable European directives is indicated by the presence of the CE mark.

2 Installation

The device has degree of protection IP20, and is therefore suitable for use in dry interior rooms. The installation of the device requires the following steps:

- a) fix the metallic support with the screws supplied on a wall box with distance between fixing holes of 60 mm. It is recommended to install the device at a height of 150 cm;
- b) if required, snap a square frame of the form or flank series, inserting it from the rear of the device;
- c) connect the sensors or the contacts required to the 4-poles screw terminal block on the rear of the device;
- d) insert the terminal for the bus (red/black), previously connected to the bus cable, in its slot on the rear side. At this point it is recommended to carry out the commissioning of the device or at least the download of the physical address;
- e) install the device on the metallic support through the spring system, tightening then the two screws
- f) requires also to tighten the screws included in the delivery. For mounting the device follow also the indication TOP (arrow tip pointing up) on the rear side of the device;.
- g) snap the two rockers onto the device for the operation of the room temperature controller.

The device can only be mounted on a round or square wall flush mounting box with 60 mm distance between fixing holes. If necessary, the metallic support for mounting on the wall box can also be ordered separately.



Note on mounting screws

The screws for the metal support must be tightened with a max. torque of 1.0 Nm.

2.1 Connection

For the operation the device has to be connected to the bus line and addressed, configured and commissioned with ETS (Engineering Tool Software). The connection of one or two sensors to the inputs is optional and must be defined by the planner of the bus system.

2.1.1 Connection of the bus line

The connection of the KNX bus line is made with the terminal block (red/black) included in delivery and inserted into the slot of the housing.

Characteristics of the KNX terminal block

- spring clamping of conductors
- 4 seats for conductors for each polarity
- terminal suitable for KNX bus cable with single-wire conductors and diameter between 0.6 and 0.8 mm
- recommended wire stripping approx. 5 mm
- color codification: red = + (positive) bus conductor, black = - (negative) bus conductor

2.1.2 Connection of the inputs

The connection of the inputs is made with the screw terminals located at the rear side of the device. The maximum cable length is 10 m. For the connection use a cable of max section 1,5 mm². The connection cable must have sufficient length to allow the extraction of the device from the wall-mounting box.

Characteristics of the terminal blocks for the inputs

- screw clamping of conductors
- maximum cross section of conductor 1 mm² (multiwire)
- recommended wire stripping approx. 5 mm
- torque max 0.2 Nm

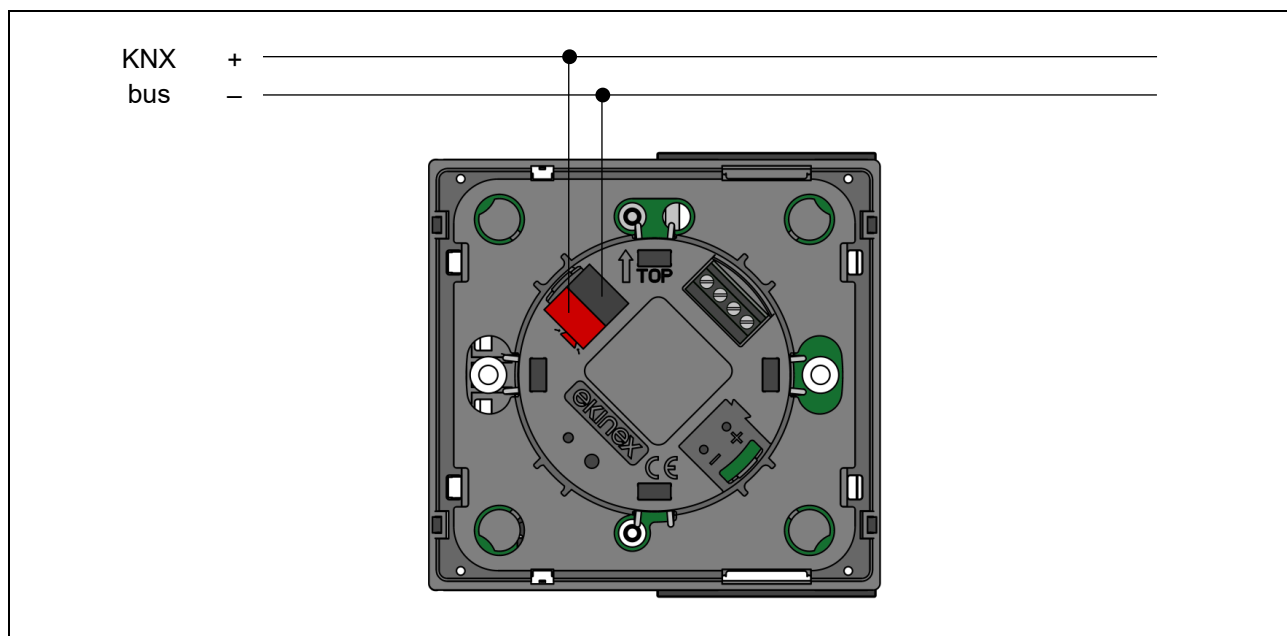

Connection of the device of the bus line

3 Configuration and commissioning

The configuration and commissioning are carried out with the ETS (Engineering Tool Software) tool and the ekinex® application program provided free of charge by Ekinex S.p.A.; you do not need any additional software neither plug-in tool. For further information on ETS see also www.knx.org.

3.1 Configuration

The device functionality is defined by the settings done via software. The configuration requires necessarily ETS4 (or later releases) and the ekinex® **APEKEQ2TP##.knxprod** (## = release) application program that can be downloaded from the website www.ekinex.com. The application program allows the configuration of all working parameters for the device. The device-specific application program has to be loaded into ETS or, as alternative, the whole ekinex® product database can be loaded; at this point, all the instances of the selected device type can be added to the project.

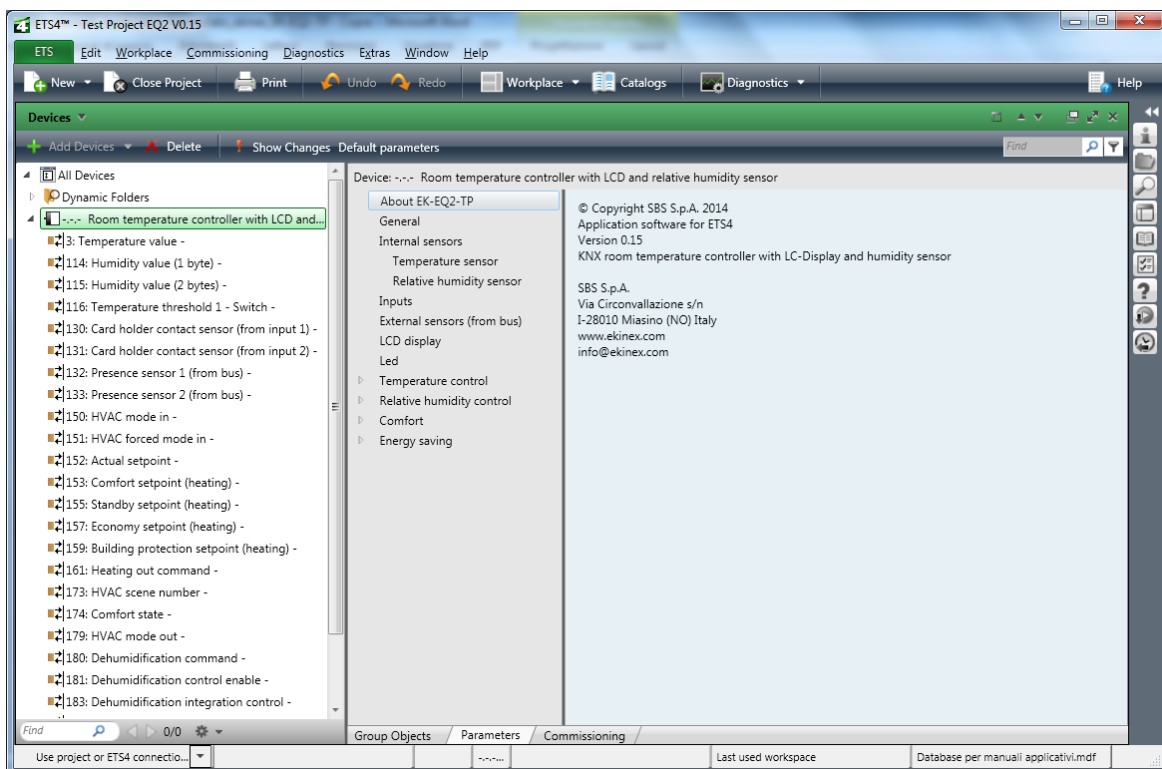

Application program for ETS APEKEQ2TP##.knxprod (## = version)

3.1.1 Tree structure of the application program

At its opening, the tree structure of the program includes the following main items:

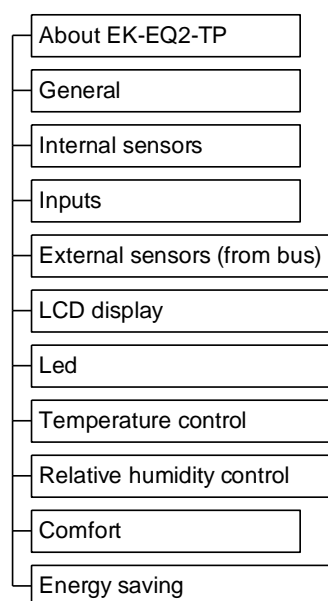

Other items may appear depending on the choices done for the parameters in the several folders.

3.1.2 Languages of the application program

The application program is available in four languages: English, Italian, German and French. The language displayed can be changed in ETS choosing "Settings / Presentation language".

3.2 Commissioning

For the commissioning the device is provided on the front side (in the area usually occupied by the rockers) with:

- a red LED (1) for indication of the active operating mode (LED on = programming, LED off = normal operation);
- a pushbutton (2) for switching between the normal and programming operating mode.

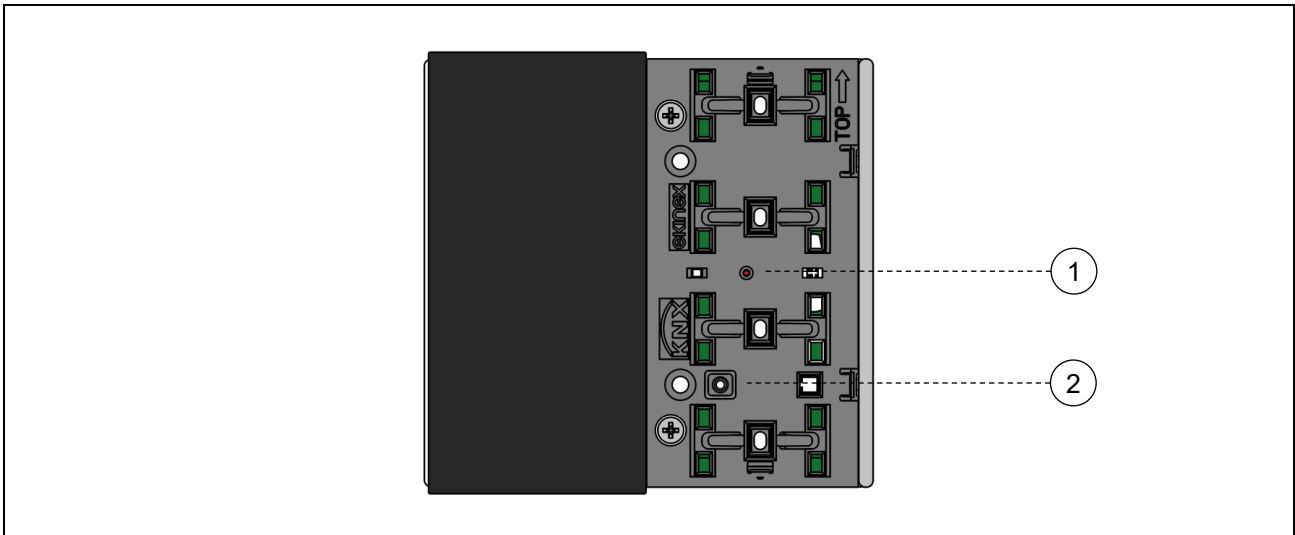

Device programming: led (1) and pushbutton (2)



For commissioning the device the following activities are required:

- make the electrical connections;
- turn on the bus power supply;
- switch the device operation to the programming mode by pressing the programming pushbutton located on the front side of the housing. In this mode of operation, the programming LED is turned on;
- download into the device the physical address and the configuration with the ETS® program.

When downloading the application program the display shows "PrOg" and the flashing symbol of the clock. At the end of the download the operation of the device automatically returns to normal mode; in this mode the programming LED is turned off. Now the bus device is programmed and ready for use.

3.2.1 Displaying physical address and firmware release

Once the first addressing is done, you can check anytime the physical address and the firmware release directly on the device display. In order to display it, press for more than 3 seconds the – (minus) symbol on the lower rocker and the ●●●● symbol on the upper rocker. All segments of the display are turned off; displaying a physical address only the 3 large digits and the small one are active. The information displayed in sequence are: the area number (A), the line number (L), the device number (d) and the firmware release (F). To scroll through the three elements of the physical address press + or –.



Example of displaying the physical address 10.5.43 (device nr. 43, installed on the line 5 of the area 10) and the firmware release 001

To exit from the physical address displaying press shortly (< 3 seconds) the ●●● symbol on the lower rocker. If you elapse of time interval set in parameter “Time to exit change without saving” without pressing any rocker, the device returns automatically to the previously displayed information.

4 User interface

The user interface of the room temperature controller includes a LC-display, a pushbutton with two rockers and a series of freely programmable LEDs (4 for each rocker). The colour of the LEDs depend on the device version.

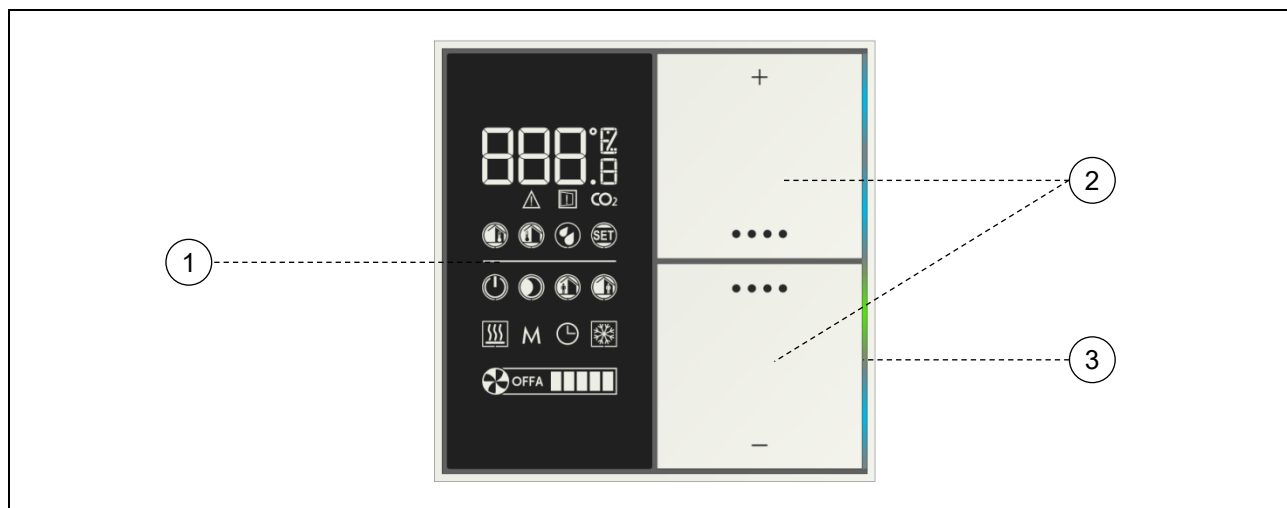

User interface: LC-display (1), rockers (2), LEDs (3) with lightguide

The symbols on the rockers recall the function carried out:

- + temperature (or other parameters) increase;
- temperature (or other parameters) decrease;
- information sequence, operating mode change, ventilation control, seasonal change-over.

Through a combined pressure of various symbols other functions can be carried out.

4.1 LCD-display

The device is provided with a LC-display (1) with adjustable backlight that occupies a vertical area of approx. 40 x 80 mm (WxH) in the left half of the device.

4.1.1 Information displaying

Depending on the configuration done with ETS, the connections and the availability of information (local or received from the bus), the series of symbols allow to display:

- room actual temperature (it may be the temperature calculated using a weighted average of two values);
- outdoor temperature, preceded by a – (minus) sign in case of outdoor temperature below 0°C;
- relative humidity (in %, without decimals);
- perceived temperature (estimated with the measured values of temperature and relative humidity);
- temperature setpoint (for the actual operating mode);
- concentration of CO₂ (in ‰);
- alarm and error condition (A01, A02... E01, E02...);
- window opening;

- operating mode (comfort / standby / economy / building protection);
- seasonal mode (heating / cooling);
- device status calling / not calling (or setpoint reached / not reached);
- operation in manual mode (M);
- operation as slave device (clock);
- fan status (1-2-3-automatic-off), when present;
- device physical address assigned by ETS.

Display symbols			
	Digits (for numeric values display)		Economy operating mode (night)
	Celsius degrees		Standby operating mode
	Fahrenheit degrees		Comfort operating mode
	Percentage (relative humidity)		Heating mode active (device not calling or setpoint reached)
	Per mille (only for CO ₂ concentration)		Heating mode active (device calling or setpoint not reached)
	Alarm		Manual operation (M)
	Window opening		Slave (operation subordinated to a supervising KNX device)
	Carbon-dioxide (CO ₂)		Cooling mode active (device not calling or setpoint reached)
	Indoor temperature		Cooling mode active (device calling or setpoint not reached)
	Outdoor temperature		OFF (fan-coil switched off)
	Relative humidity		Automatic fan-coil operation (example: speed 3)
	SET		Manual fan-coil operation (example: speed 2)
	Building protection operating mode (off)		

Symbols that can be activated on the LC-display

4.1.2 Segment test

The segment test allows you to check at any time the proper functionality of the display. In order to do the test, press simultaneously + (plus) on the upper rocker and the symbol ●●● on the lower rocker for more

than 3 seconds. All symbols are activated simultaneously; then all the symbols are turned off. In the test phase keep available the instructions or the user guide.

If you elapse the time set in the parameter "Time to exit change without saving" (General folder) without pressing a button, the device will return to the previous situation.

4.1.3 Backlight

The backlight intensity of the LC-display is adjustable. The first setting is done when configuring the device using ETS, but the intensity can be changed later at any time.

To access the change press simultaneously + (plus) and ●●●● (bothon the upper rocker) for more than 3 seconds. All symbols are turned off except the digits and the percentage symbol. The actual value (as a percentage) of backlight intensity is displayed. At each pressing of + or – the intensity is increased or decreased by 5%. To confirm the selected intensity press shortly (< 3 seconds) the ●●●● symbol either on the upper rocker. Three rapid flashes of the digits indicate that the new value was saved. If you elapse of time interval set in the "Time to exit change without saving " (General folder) without pressing any rocker, the device returns to the previous situation.

4.2 Rockers

The pushbutton with two rockers integrated in the device controls the functions of the thermostat. The set of two rockers has to be ordered separately; the symbols on the rockers of the set are pre-defined and cannot be changed. The areas marked by the symbols + (plus) and – (minus) allow you to change a setting (e.g. the temperature setpoint), while those marked by the symbol ●●●● allow you to display a sequence of information, to change the operating mode, to control the ventilation, to do the seasonal change-over (heating to cooling and vice versa) or to confirm a setting change.

The part number of the set EK-TSQ-Gxx-EP2 must be completed with the part (xx) that identifies the material, color and finishing; for the exact code please refer also to the latest edition of the ekinex product catalog or the website www.ekinex.com.

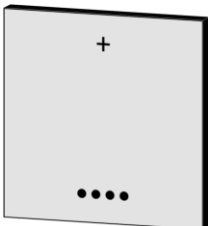
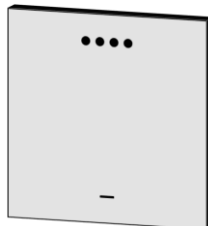
Rockers use	Upper rocker	Lower rocker
Functions for room temperature controlling	 + and ●●●●	 ●●●● and –

5 Sensors

The room temperature controller is equipped with three sensors:

- temperature (1);
- relative humidity (2).

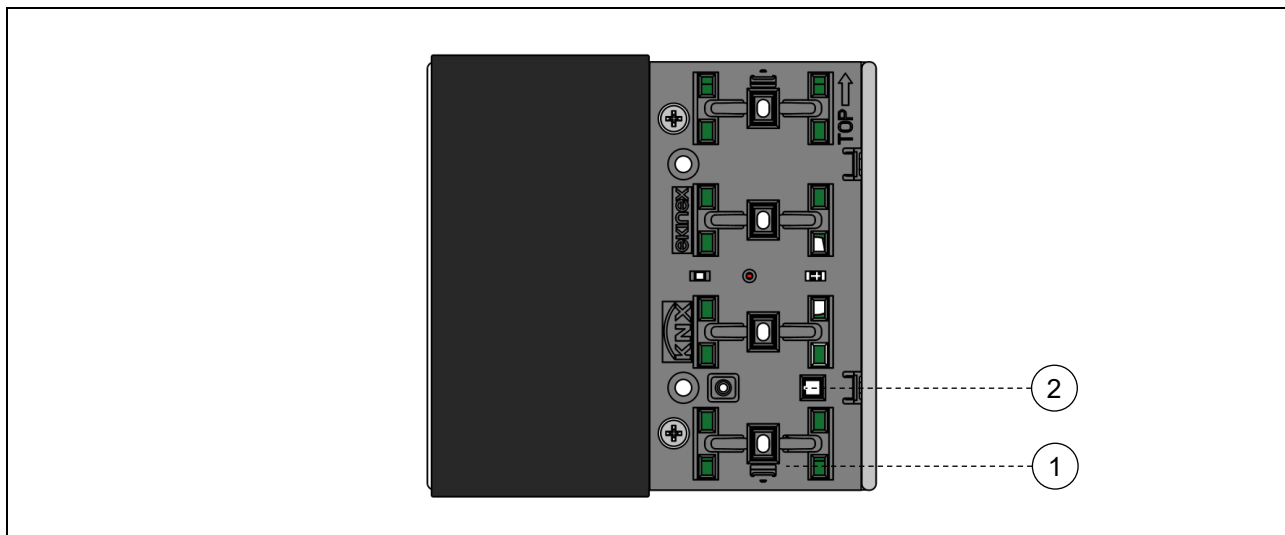

Position of the sensors: temperature (1), relative humidity (2).

The temperature sensor (not to be seen in the drawing) is located under the plastic half-shell for the rockers' mounting.

5.1 Temperature sensor

The integrated temperature sensor allows the measuring of the room temperature in the range from 0 °C to +40 °C with a resolution of 0.1 °C. To keep into account significant environmental interferences such as the proximity to heatsources, the installation on an outer wall, the chimney effect due to rising warm air through the corrugated tube connected to the wall-mounting box, the measured value can be corrected by means of a offset of ± 5 °C or, preferably, can be used a weighted average between two values of temperature chosen from the following ones: value measured by the integrated sensor, value measured by a temperature sensor connected to one of the inputs of the device, value received via bus from another KNX device (such as ekinex pushbuttons).

5.2 Relative humidity sensor

The integrated relative humidity sensor allows the measuring of the relative humidity value in the room. The measured value allows you to make an advanced room thermoregulation and enlarge the opportunities for a safe operation of certain types of terminal equipments used for cooling. The measured value can also be sent on the bus via the 114 (1 byte) and the 115 (2 bytes) Communication Objects. By means of a calculation performed by the thermostat, on the bus can also be sent psychrometric values obtained from the combined measurement of temperature and humidity, such as the dew-point temperature, as well as the index of perceived temperature (only in summer mode).

6 Input variables

The data that the device uses in its control algorithms and /or to be displayed may come from:

- the internal sensors;
- sensors or digital signals connected to the two physical inputs of the device;
- the KNX bus through standard Communication Objects.

The processed data can also be transmitted on the KNX bus as Communication Objects. The classification of the input variables is shown in the following table.

Data	Coming from	Description
Room temperature	Internal sensor	Analogic value for thermoregulation functions
Room relative humidity		Analogic value for thermoregulation functions
Window state (open/close)	Input 1 or 2 (device terminals) configured	[DI] window contact sensor
Card holder state (badge in/out)		[DI] card holder contact sensor
Presence of condensation		[DI] anticondensation sensor
Conveying fluid temperature at the exchange coil		[AI] coil battery temperature sensor
Room temperature (for weighted average value)		[AI] room temperature sensor
Room temperature (other measurement height)		[AI] antistratification temperature sensor
Floor surface temperature		[AI] floor surface temperature sensor
Outdoor temperature		[AI] outdoor temperature sensor
Further temperature value		[AI] generic (NTC) temperature sensor
Room temperature		KNX bus (through communication objects)
Room relative humidity	Objects 35 (2 bytes) and 36 (1 byte)	
Antistratification temperature	Object 37 (2 bytes)	
Outdoor temperature	Object 38 (2 bytes)	
CO ₂ concentration (air quality)	Object 39 (2 bytes)	
Conveying fluid temperature at the exchange coil	Object 40 (2 bytes)	
Floor surface temperature	Object 41 (2 bytes)	
Conveying fluid flow temperature	Object 42 (2 bytes)	
Presence of condensation	Object 46 (1 bit)	
Window state (open/close)	Objects 43 and 44 (1 bit)	
Presence of people in the room	Objects 32 and 33 (1 bit)	
Card holder state (badge in/out)	Object 45 (1 bit)	

Input variables from internal sensors, physical inputs and standard communication objects.

The device does not have outputs for direct switching or control of heating/cooling terminals or for status or values signalling. The output variables include exclusively communication objects that are sent on the bus, received and processed by KNX actuators (general-purpose or dedicated to HVAC applications).

7 Application program for ETS

In the following chapters there is the list of folder, parameters and communication objects of the application program. Some specific functions of the thermostat are described in more detail in the dedicated paragraphs. The tree structure of the application program as imported into ETS (or by pressing the "Default Parameters" button of ETS) is the following:

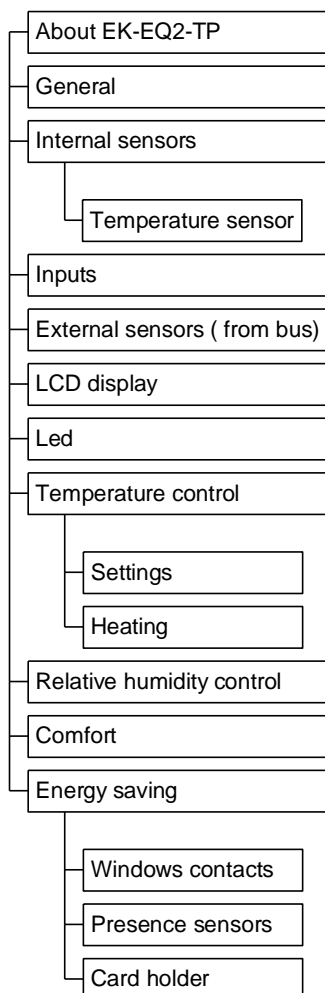

Other folders may appear depending on the choices done for the parameters of the folders represented in the main tree structure.

7.1 About EK-EQ2-TP

The folder **About EK-EQ2-TP** is for information purposes only and does not contain parameters to be set. The information given is:

© Copyright Ekinex S.p.A. 2022
 Application software for ETS4 and ETS5
 Version 4.00 (or later)
 KNX room temperature controller with LC-display and humidity sensor
 Ekinex S.p.A.
 via Novara, 37
 I-28010 Vaprio d'Agogna (NO) Italy

www.ekinex.com
info@ekinex.com

7.1.1 General

The **General** folder includes the following parameters:

- Device operation as
- Temperature displayed unit
- Default displayed information
- Time to return to default display information
- Button function level
- Time to exit change without saving
- Delay after bus voltage recovery

The folder has no secondary folders.

7.1.2 Parameters

Parameter name	Conditions	Values
Device operation as		stand-alone stand-alone/chrono slave
	<i>If configured as stand-alone/chrono the operating mode can be selected manually on the device; in that way, the commands received via bus are ignored. If changing the operating mode the watch symbol is selected, the commands received via bus are accepted again. If configured as slave, the room temperature controller receives from a KNX device (acting as supervisor) HVAC modes, setpoint values, etc.</i>	
Temperature displayed unit		Celsius Fahrenheit
Default displayed information		actual temperature temperature setpoint
	<i>The actual temperature is the value by which the device performs the temperature regulation. It may be the value measured from a single sensor (internal, from the bus or from an input) or the weighted average of the temperatures measured by a main sensor and an additional sensor. The displayed setpoint temperature is that of the operating mode currently set on the room temperature controller (deduced from the symbol on).</i>	
Time to return to default display information		5 s [other values in the range 10 s ... 1 min]
	<i>Time interval after which the display automatically switches between the manually recalled information to the default information.</i>	
Button function level		end user system integrator
	<i>This parameter allows you to partially inhibit the functions that can be recalled using the rockers.</i>	
Time to exit change without saving		8 s [other values in the range 2 s ... 12 s]
	<i>Time interval without further pressing of the rockers at the end of which the</i>	

Parameter name	Conditions	Values
	<i>device exits the procedure without saving the current changes.</i>	
Delay after bus voltage recovery		00:00:04.000 hh:mm:ss:fff [range 00:00:04.000 ... 00:10:55.350]
	<i>Time interval after which the transmission of the telegrams on the bus starts after the power supply is restored. The delay affects both the event-driven transmission and the cyclic transmission of a telegram. Regarding the latter, the counting of the pause interval for retransmission starts at the end of the time of initial delay.</i> <i>The field has format hh:mm:ss:fff (hours : minutes : seconds .milliseconds): the default value 00:00:04.000 corresponds to 4 seconds.</i>	
Logic functions		disabled / enabled
	<i>Enable tab to configure logic functions AND, OR, XOR 8-channel (4 inputs for channel)</i>	

Information displayed as default

One information between the *actual temperature* and the *temperature setpoint* is displayed preferably by the digits of the display. The device allows you to retrieve and display a series of other information pressing the ●●●● symbol on the upper rocker; after the time set in the parameter "Time to return to default information" without further pressure of ●●●●, the display automatically returns to the default information.

Functional level of the rockers

The use of the rockers for controlling the room temperature controller can be partially inhibited in the configuration phase through a filter for the access to the several functions. When using the rockers a distinction is made between:

- first level functions (= short or long pressing of the rockers) for the end user;
- second level functions (= combination of rockers); to the first level are added a few functions for a system integrator or an installer.

The enabled functional level is set through a special parameter.

7.2 Internal sensors

The **Internal sensors** folder includes the following parameters:

- Temperature sensor
- Relative humidity sensor

7.2.1 Parameters

Parameter name	Conditions	Values
Temperature sensor		enabled disabled
	<p>The temperature sensor is enabled as default.</p> <p>When the sensor is disabled, the corresponding folder disappears from the main tree structure of the application program; in this case to have available again the functions for Temperature control you have to enable Room temperature in the External sensors (from bus) folder or set Input X = [AI] temperature sensor (X = 1, 2) in the Inputs folder.</p>	
Relative humidity sensor		disabled enabled
	<p>The relative humidity sensor is disabled as default.</p> <p>When the sensor is disabled, the functions that require the value of relative humidity are available only if you enable Relative humidity in the External sensors (from bus) folder.</p> <p>When the sensor is enabled, the corresponding folder appears in the main tree structure of the application program.</p>	

7.2.2 Temperature sensor

The **Temperature sensor** secondary folder appears only if the corresponding sensor is enabled in the folder **Internal sensors** and includes the following parameters:

- Filter type
- Temperature offset
- Minimum change of value to send [K]
- Cyclic sending interval
- Threshold 1
- Threshold 2

7.2.2.1 Parameters and communication objects

Parameter name	Conditions	Values
Filter type	Temperature sensor = enabled	low medium high
	<p>Low = average value every 4 measurements Medium = average value every 16 measurements High = average value every 64 measurements</p>	
Temperature offset	Temperature sensor = enabled	0°C [range -5°C ... +5°C]
	It allows to apply an offset to the temperature value measured by the sensor	
Minimum change of value to send [K]	Temperature sensor = enabled	0,5 [range 0 ...5]
	If the parameter is set to 0 (zero), no value is sent after a change.	

Parameter name	Conditions	Values
Cyclic sending interval	Temperature sensor = enabled	no sending [other values in the range 30 s ... 120 min]
Threshold 1	Temperature sensor = enabled	not active below above
Value [°C]	Temperature sensor = enabled, Threshold 1 = below or above	7 [range 0 ... 50]
Threshold 2	Temperature sensor = enabled	not active below above
Value [°C]	Temperature sensor = enabled, Threshold 2 = below or above	45 [range 0 ... 50]
Hysteresis	Temperature sensor = enabled, Threshold 1 and/or Threshold 2 = below or above	0,4 K [other values between 0,2 K and 3 K]
Cyclic sending interval	Temperature sensor = enabled, Threshold 1 and/or Threshold 2 = below or above	no sending [other values in the range 30 s ... 120 min]

Object name	Conditions	Dim.	Flags	DPT	Comm. Obj. No.
Temperature value	Temperature sensor = enabled	2 Bytes	CR-T--	[9.001] temperature (°C)	3
Temperature threshold1 - Switch	Temperature sensor = enabled, Threshold 1 = below or above	1 Bit	CR-T--	[1.001] switch	16
Temperature threshold2 - Switch	Temperature sensor = enabled, Threshold 2 = below or above	1 Bit	CR-T--	[1.001] switch	17

Acquisition filter

The acquisition filter calculates an average with a series of measured values before sending on the bus. The parameter can have the following values:

- low = average value every 4 measurements;
- medium = average value every 16 measurements;
- high = average value every 64 measurements.

Correction of the measured temperature

The sampling of the temperature value occurs every 10 seconds, while the display is updated every minute. During the configuration with ETS the opportunity is given to correct the measured temperature value within the offset range of - 5 °C ... + 5 °C (step: 0.1 °C).

7.2.3 Relative humidity sensor

The secondary folder **Relative humidity sensor** appears only if the corresponding sensor is enabled in the folder **Internal sensors** and includes the following parameters:

- Filter type
- Humidity offset
- Minimum change of value to send [%]
- Cyclic sending interval
- Threshold 1
- Threshold 2

For single parameters are valid the indications given for the same parameters of the temperature sensor.

Correction of the measured relative humidity

The folder of the relative humidity sensor has a parameter correction value (offset): during the configuration with ETS the opportunity is given to correct the measured relative humidity value within the offset range of -10 % ... +10 % (step: 1 %).

The humidity sensor used is calibrated at the factory.

7.2.3.1 Parameters and communication objects

Parameter name	Conditions	Values
Filter type	Relative humidity sensor = enabled	low medium high
	<i>Low = average value every 4 measurements Medium = average value every 16 measurements High = average value every 64 measurements</i>	
Humidity offset	Relative humidity sensor = enabled	0 % [range -10 % ... +10 %]
	<i>It allows you to apply an offset to the relative humidity value measured by the sensor</i>	
Minimum change of value to send [%]	Relative humidity sensor = enabled	2 [range 0 ...10]
	<i>If the parameter is set to 0 (zero), no value is sent after a change.</i>	
Cyclic sending interval	Relative humidity sensor = enabled	no sending [other values in the range 30 s ... 120 min]
Threshold 1	Relative humidity sensor = enabled	not active below above
Value [%]	Relative humidity sensor = enabled, Threshold 1 = below or above	65 [range 0 ... 100]
Threshold 2	Relative humidity sensor = enabled	not active below above
Value [%]	Relative humidity sensor = enabled, Threshold 2 = below or above	65 [range 0 ... 100]

Parameter name	Conditions	Values
Hysteresis [%]	Relative humidity sensor = enabled, Threshold 1 or Threshold 2 = below or above	3,0 % [other values in the range 0,5 ... 4,0 %]
<i>The value of the parameter Hysteresis is common for both parameters Threshold 1 and Threshold 2.</i>		
Cyclic sending interval	Relative humidity sensor = enabled, Threshold 1 or Threshold 2 = below or above	no sending [other values in the range 30 s ... 120 min]
<i>The value of the parameter Cyclic sending interval is common for both parameters Threshold 1 and Threshold 2.</i>		

Object name	Conditions	Dim.	Flags	DPT	Comm. Obj. No.
Humidity value (1 byte)	Relative humidity sensor = enabled, Dimension of the C. O. = 1 byte	1 Byte	CR-T--	[5.001] percentage (0..100%)	14
Humidity value (2 byte)	Relative humidity sensor = enabled, Dimension of the C. O. = 2 Byte	2 Byte	CR-T--	[9.007] percentage (%)	15
Temperature threshold 1 - switch	Relative humidity sensor = enabled, Threshold 1 = below or above	1 Bit	CR-T--	[1.001] switch	18
Temperature threshold 2 - switch	Relative humidity sensor = enabled, Threshold 2 = below or above	1 Bit	CR-T--	[1.001] switch	19

7.3 Inputs

The folder **Inputs** allows you to configure one or two variables (either digital or analogic) depending on the digital signals or the temperature sensors connected to the terminal blocks of the inputs. The physical values or the detected states can be used locally by the device for temperature control functions and/or transmitted on the bus for other purposes. The folder includes the parameters for configuring independently the inputs 1 and 2. The two inputs are identical; for simplicity in the following only parameters and communication objects of a single input are described.

7.3.1 Input X

The folder **Input X** (X = 1, 2) includes the following parameters:

- Input X
- Contact type
- Filter type
- Temperature offset
- Cyclic sending interval
- Minimum change of value to send (K)
- Threshold 1
- Value [°C]
- Threshold 2
- Value [°C]
- Hysteresis
- Cyclic sending interval

7.3.2 Parameters and communication objects

Parameter name	Conditions	Values
Input X		<p>disabled</p> <p>[DI] window contact sensor [DI] card holder contact sensor [DI] anticondensation sensor [AI] coil battery temperature sensor [AI] room temperature sensor [AI] antistratification temperature sensor [AI] floor surface temperature sensor [AI] outdoor temperature sensor [AI] generic (NTC) temperature sensor</p>
<i>The [DI] prefix indicates a digital input, the [AI] prefix an analogic input.</i>		
Contact type	Input X = [DI] ...	<p>NO (normally open) NC (normally closed)</p>
<i>This parameter is always available when the input is configured as digital.</i>		
Debounce time	Input X = [DI] ...	<p>00:00:00.200 hh:mm:ss.fff [range 00:00:00.000 ... 00:10:55.350]</p>
<i>This parameter is always available when the input is configured as digital. The field has format hh:mm:ss:fff (hours : minutes : seconds . milliseconds): the default value 00:00:00.200 corresponds to 200 milliseconds.</i>		

Parameter name	Conditions	Values
Filter type	Input X = [AI] ...	low medium high
	<i>This parameter is always available when the input is configured as analogic. Low = average value every 4 measurements Medium = average value every 16 measurements High = average value every 64 measurements</i>	
Offset temperature	Input X = [AI] ...	0°C [range -5°C ... +5°C]
	<i>This parameter is always available when the input is configured as analogic.</i>	
Minimum change of value to send [K]		0,5 [range 0 ...5]
	<i>This parameter is always available when the input is configured as analogic. When set to 0 (zero), no value is sent at a change.</i>	
Cyclic sending interval	Input X different from disabled	no sending [other values in the range 30 s ... 120 min]
Threshold 1	Input X = [AI] ...	not active / below / above
	<i>This parameter is always available when the input is configured as analogic.</i>	
Value [°C]	Input X = [AI] ... Threshold 1 = below or above	7 [range 0 ... 50]
Threshold 2	Input X = [AI] ...	not active / below / above
	<i>This parameter is always available when the input is configured as analogic.</i>	
Value [°C]	Input X = [AI] ... Threshold 2 = below or above	45 [range 0 ... 50]
Hysteresis	Input X = [AI] ... Threshold 1 = below or above Threshold 2 = below or above	0,4 K [other values in the range 0,2 K ... 3 K]
Cyclic sending interval	Input X = [AI] ... Threshold 1 = below or above Threshold 2 = below or above	no sending [other values in the range 30 s ... 120 min]

Object name	Conditions	Dim.	Flags	DPT	Comm. Obj. No.
Window contact sensor (from input 1)	Input 1 = [DI] windows contact sensor	1 Bit	CR-T--	[1.019] window/door	26
Window contact sensor (from input 2)	Input 2 = [DI] windows contact sensor	1 Bit	CR-T--	[1.019] window/door	27
	<i>If both inputs (1 and 2) are configured in the same way, only the first one is used by the device.</i>				
Anticondensation sensor (from input 1)	Input 1 = [DI] anticondensation sensor	1 Bit	CR-T--	[1.005] alarm	28
Anticondensation sensor (from input 2)	Input 2 = [DI] anticondensation sensor	1 Bit	CR-T--	[1.005] alarm	29
	<i>If both inputs (1 and 2) are configured in the same way, only the first one is used by the device.</i>				
Card holder contact sensor (from input 1)	Input 1 = [DI] card holder contact sensor	1 Bit	CR-T--	[1.018] occupancy	30
Card holder contact sensor	Input 2 = [DI] card holder contact	1 Bit	CR-T--	[1.018] occupancy	31

Object name	Conditions	Dim.	Flags	DPT	Comm. Obj. No.
(from input 2)	sensor				
<i>If both inputs (1 and 2) are configured in the same way, only the first one is used by the device.</i>					
Coil battery temperature sensor (from input 1)	Input 1 = [AI] coil battery temperature sensor	2 Byte	CR-T--	[9.001] temperature (°C)	20
Coil battery temperature sensor (from input 2)	Input 2 = [AI] coil battery temperature sensor	2 Byte	CR-T--	[9.001] temperature (°C)	23
<i>If both inputs (1 and 2) are configured in the same way, only the first one is used by the device.</i>					
Temperature value sensor (from input 1)	Input 1 = [AI] room temperature sensor	2 Byte	CR-T--	[9.001] temperature (°C)	20
Temperature value sensor (from input 2)	Input 2 = [AI] room temperature sensor	2 Byte	CR-T--	[9.001] temperature (°C)	23
<i>If both inputs (1 and 2) are configured in the same way, only the first one is used by the device.</i>					
Antistratification temperature sensor (from input 1)	Input 1 = [AI] antistratification temperature sensor	2 Byte	CR-T--	[9.001] temperature °C	20
Antistratification temperature sensor (from input 2)	Input 2 = [AI] antistratification temperature sensor	2 Byte	CR-T--	[9.001] temperature °C	23
<i>If both inputs (1 and 2) are configured in the same way, only the first one is used by the device.</i>					
Floor surface temperature sensor (from input 1)	Input 1 = [AI] floor surface temperature sensor	2 Byte	CR-T--	[9.001] temperature °C	20
Floor surface temperature sensor (from input 2)	Input 2 = [AI] floor surface temperature sensor	2 Byte	CR-T--	[9.001] temperature °C	23
<i>If both inputs (1 and 2) are configured in the same way, only the first one is used by the device.</i>					
Outdoor temperature sensor (from input 1)	Input 1 = [AI] outdoor temperature sensor	2 Byte	CR-T--	[9.001] temperature °C	20
Outdoor temperature sensor (from input 2)	Input 2 = [AI] outdoor temperature sensor	2 Byte	CR-T--	[9.001] temperature °C	23
<i>If both inputs (1 and 2) are configured in the same way, only the first one is used by the device.</i>					
Temperature value sensor (from input 1)	Input 1 = [AI] generic (NTC) temperature sensor	2 Byte	CR-T--	[9.001] temperature °C	20
Temperature value sensor (from input 2)	Input 2 = [AI] generic (NTC) temperature sensor	2 Byte	CR-T--	[9.001] temperature °C	23
<i>If both inputs (1 and 2) are configured in the same way, only the first one is used by the device.</i>					
Temperature threshold 1 sensor 1 - Switch	Input 1 = [AI] ... Threshold 1 = below or above, Threshold 2 = below or above	1 Bit	CR-T--	[1.001] switch	21
Temperature threshold 2 sensor 1 - Switch	Input 1 = [AI] ... Threshold 1 = below or above, Threshold 2 = below or above	1 Bit	CR-T--	[1.001] switch	22

<i>Object name</i>	<i>Conditions</i>	<i>Dim.</i>	<i>Flags</i>	<i>DPT</i>	<i>Comm. Obj. No.</i>
Temperature threshold 1 sensor 2 - Switch	Input 2= [AI] ... Threshold 1 = below or above, Threshold 2 = below or above	1 Bit	CR-T--	[1.001] switch	24
Temperature threshold 2 sensor 2 - Switch	Input 2= [AI] ... Threshold 1 = below or above, Threshold 2 = below or above	1 Bit	CR-T--	[1.001] switch	25

7.4 External sensors (from bus)

As “external sensors” are intended KNX-devices (or conventional sensors interfaced to the bus through KNX devices) which send states or values to the room temperature controller via the bus. Enabling an external sensor, without connecting the corresponding communication object, generates a permanent alarm on the display and suspends the thermoregulation function.

The folder **External sensors (from bus)** includes the following parameters:

- Room temperature
- Antistratification temperature
- Outdoor temperature
- Air quality
- Floor surface temperature
- Flow temperature
- Anticondensation
- Window contact X (X = 1, 2)
- Presence sensor X (X = 1, 2)
- Card holder contact
- Analog sensor timeout
- Digital sensor timeout

The folder does not have any secondary folder.

7.4.1 Parameters and communication objects

Parameter name	Conditions	Values
Room temperature		disabled / enabled
	<i>It enables a bus temperature sensor. The measured value can be used to calculate a weighted average value in combination with the temperature sensor integrated into the device or a temperature sensor connected to a device input.</i>	
Relative humidity	Internal sensors ⇒ Relative humidity sensor = disabled	disabled / enabled
	<i>It enables a relative humidity bus sensor to be used alternatively to the sensor integrated into the device.</i>	
Humidity C.O. dimension	Relative humidity = enabled	1 byte (DPT 5.001) 2 bytes (DPT 9.007)
Antistratification temperature		disabled / enabled
	<i>It enables a temperature bus sensor to carry out the antistratification function.</i>	
Outdoor temperature		disabled / enabled
	<i>It enables an outdoor temperature bus sensor to display the measured value on the display. This is alternative to an outdoor temperature sensor connected to a device input: the parameter appears only if the external temperature sensor is disabled in the Inputs folder.</i>	
Air quality		disabled / enabled
	<i>It enables an air quality bus sensor to display the measured value (CO₂ concentration) on the display.</i>	
Coil temperature		disabled / enabled
	<i>It enables a bus sensor for measuring the conveying fluid temperature at the coil for heat exchange. The acquisition of the value allows realizing the hot-start function of a fan.</i>	

Parameter name	Conditions	Values
Floor surface temperature		disabled / enabled
	<i>It enables a bus sensor for measuring the surface temperature of a floor heating system. The acquisition of the value allows to realize the function of surface temperature limitation.</i>	
Flow temperature		disabled / enabled
	<i>It enables a bus sensor for measuring the conveying fluid temperature. The acquisition of the value is used to calculate the dew-point temperature and to realize the function of protection from condensation of activetype in surface (floor or ceiling) cooling systems.</i>	
Analogic sensors timeout		00:05:00hh:mm:ss [range 00:00:00 ... 18:12:15]
	<i>The field has format hh:mm:ss (hours : minutes : seconds): the default value 00:05:00 corresponds to a timeout of 5 minutes. The value 00:00:00 means that the timeout of the analogic sensors is disabled.</i>	
Anticondensation		disabled / enabled
	<i>It enables a bus sensor for detecting the condensation.</i>	
Window contact 1		disabled / enabled
	<i>It enables a bus sensor for detecting the state of opening / closing of a window or a door.</i>	
Window contact 2		disabled / enabled
	<i>It enables a bus sensor for detecting the state of opening / closing of a window or a door.</i>	
Presence sensor 1		disabled / enabled
	<i>It enables a bus sensor for detecting the presence / absence of people within a room.</i>	
Presence sensor 2		disabled / enabled
	<i>It enables a bus sensor for detecting the presence / absence of people within a room.</i>	
Card holder contact		disabled / enabled
	<i>It enables a bus sensor for detecting the presence / absence of people in a hotel room provided with a card holder.</i>	
Digital sensors timeout		00:05:00hh:mm:ss [range 00:00:00 ... 18:12:15]
	<i>The field has format hh:mm:ss (hours : minutes : seconds): the default value 00:05:00 corresponds to a timeout of 5 minutes. The value 00:00:00 means that the timeout of the digital sensors is disabled.</i>	

Object name	Conditions	Dim.	Flags	DPT	Comm. Obj. No.
Room temperature (from bus)	enabled	2 Byte	C-W---	[9.001] temperature (°C)	34
Humidity (2 bytes, from bus)	Relative humidity sensor = enabled, Humidity C.O. dimension = 2 bytes	2 Byte	C-W---	[9.007] percentage (%)	35
Humidity (1 byte, from bus)	Relative humidity sensor = enabled, Humidity C.O. dimension = 1 byte	1 Byte	C-W---	[5.001] percentage (0..100%)	36
Antistratification temperature (from bus)	enabled	2 Byte	C-W---	[9.001] temperature (°C)	37

Object name	Conditions	Dim.	Flags	DPT	Comm. Obj. No.
Outdoor temperature (from bus)	enabled	2 Byte	C-W---	[9.001] temperature °C	38
Air quality (from bus)	enabled	2 Byte	C-W---	[9.008] parts/million (ppm)	39
Coil temperature (from bus)	enabled	2 Byte	C-W---	[9.001] temperature (°C)	40
Floor temperature (from bus)	enabled	2 Byte	C-W---	[9.001] temperature (°C)	41
Flow temperature (from bus)	enabled	2 Byte	C-W---	[9.001] temperature (°C)	42
Anticondensation (from bus)	enabled	1 Bit	C-W---	[1.001] switch	46
Windows contact sensor 1 (from bus)	enabled	1 Bit	C-W---	[1.019] window/door	43
Windows contact sensor 2 (from bus)	enabled	1 Bit	C-W---	[1.019] window/door	44
Presence sensor 1 (from bus)	enabled	1 Bit	C-W---	[1.018] occupancy	32
Presence sensor 2 (from bus)	enabled	1 Bit	C-W---	[1.018] occupancy	33
Contact of card holder (from bus)	enabled	1 Bit	C-W---	[1.001] switch	45

About the sensor timeout

The system of internal control of the thermostat monitors cyclically the updating status of the values of the external sensors (from bus) and the inputs when the timeout setting expires. In case no updated value has been received, the regulation function is suspended, an alarm is displayed on the display through the symbol and the corresponding alarm code (see also the list of alarms in the paragraph Diagnostics).

7.5 Weighted temperature value

The **Weighted temperature value** folder appears only if two sensors for measuring the room temperature are enabled and includes the following parameters:

- Main source for temperature value
- Additional source temperature value
- Relative weight
- Minimum change of value to send [K]
- Cyclic sending interval

7.5.1 Parameters and communication objects

Parameter name	Conditions	Values
Main source for temperature value		*
	*) The values that can be set depend on enabling the internal sensor, the inputs or the external sensors (from bus).	
Additional source temperature value		*
	*) The values that can be set depend on enabling the internal sensor, the inputs or the external sensors (from bus).	
Relative weight		100% main sensor 90% / 10% 80% / 20% 70% / 30% 60% / 40% 50% / 50% 40% / 60% 30% / 70% 20% / 80% 10% / 90% 100% additional sensor
Minimum change of value to send [K]		0,5 [other values in the range 0 ... 5 K]
	If the parameter is set to 0 (zero), no value is sent at the change.	
Cyclic sending interval		no sending [other values in the range 30 s ... 120 min]

Object name	Conditions	Dim.	Flags	DPT	Comm. Obj. No.
Weighted temperature	Cyclic sending interval different than no sending	2 Byte	CR-T--	[9.001] temperature °C	47

About the weighted temperature

The device allows the acquisition of the room temperature in three ways:

- 1) from the temperature sensor integrated in the device;
- 2) from an external temperature sensor connected to a device input configured as analogic (Inputs ⇒ Input 1 or 2 = [AI] room temperature sensor);
- 3) via bus from another KNX device, e.g. from an ekinex pushbutton (External sensors (from bus) ⇒ Room temperature = enabled);

To optimize or correct the room temperature regulation in special cases (in large rooms, in presence of strong asymmetry of the temperature distribution, when the installation of the device is in a position not suitable, etc.), the device can then use a weighted average between two temperature values. The weights are assigned by the parameter *Relative weight* that assigns a ratio of the two values.

7.6 LCD-display

The folder **LCD display** includes the following parameters:

- Backlight intensity
- Automatic backlight dimming
- Energy saving
- Visualisation type
- Time before energy saving mode
- Backlight when in energy saving mode
- Behaviour on button press
- Actual temperature (always displayed)
- Temperature setpoint
- Perceived temperature
- Relative humidity
- Relative humidity setpoint
- Air quality

Energy saving mode

After a configurable time interval, the room temperature controller switches from normal to energy saving operation. In this display mode:

- the backlight intensity may be reduced;
- the information content to be displayed may be reduced (two options: partial and temperature only).

Backlight

The default backlight of the display can be configured according to the installation location and light conditions of the room. The backlight intensity can be set to a fixed value (in %).

Information to be displayed

The actual temperature is always displayed; in addition, and depending on individual preferences, other information can be displayed in sequence: the setpoint temperature (for the current operating mode), the perceived temperature, the relative humidity, the relative humidity setpoint and the air quality.

7.6.1 Parameters

Parameter name	Conditions	Values
Backlight intensity		10% / 20% / 30% / 40% / 50% / 60% / 70% / 80% / 90% / 100%
Energy saving		disabled / enabled
	<i>If the parameter Energy saving = enabled, after a certain time interval the device automatically reduces the backlight intensity and possibly the information content displayed.</i>	
Visualisation type	Energy saving = enabled	full temperature only
	<i>In addition to the digits, "temperature only" includes the symbol (°C or °F).</i>	
Time before energy saving mode	Energy saving = enabled	10 s / 15 s / 30 s 45 s / 1 min

Parameter name	Conditions	Values
Backlight when in energy saving mode	Energy saving = enabled	off / 2% / 5% / 10% / 15% / 20% / 25% / 30%
Behaviour on button press	Energy saving = enabled	backlight only backlight and button function
	<i>It defines the reaction at the first press of a rocker when the device is in energy saving mode.</i>	
Temperature setpoint	At least one temperature sensor enabled (internal, external from bus, from an input)	enable / disabled
Perceived temperature	A temperature sensor and a relative humidity sensor enabled (internal, external from bus, from an input)	enable / disabled
Relative humidity	At least one relative humidity sensor enabled (internal or external from bus)	enable / disabled
Relative humidity setpoint	At least one relative humidity sensor enabled (internal or external from bus)	enable / disabled
Air quality	External sensors (from bus) ⇒ Air quality = enabled	enable / disabled

7.7 Leds

Each pushbutton channel has four programmable leds; for example, for status feedback of the controlled loads or for orientation nightlight. The light emitted by the leds is diffused by means of an appropriate lightguide.

The folder **Led** includes the following parameters:

- Leds intensity from bus
- Leds intensity
- Led first colour XY (X = 1, 2; Y= A, B)
- Led second colour XY (X = 1, 2; Y= A, B)
- Off delay
- Always
- Blinking
- Blinking period / type
- Signal from bus
- Technical alarm

7.7.1 Parameters and communication objects

Parameter name	Conditions	Values
Leds intensity from bus		no / yes
	<i>It enables receiving from the bus of the light intensity value emitted by the leds.</i>	
Leds intensity	Leds intensity from bus = no	50% [range 0% ... 100%]
	<i>It allows setting the light intensity value emitted by the leds (if not received from the bus).</i>	
Led first colour XY		fixed when contact close status from bus
	<i>X = 1, 2; Y= A, B</i>	
Off delay	Led first colour XY = when contact close	00:00:02:00 hh:mm:ss:ff [other values in the range 00:00:00:00 ... 01:49:13:50]
Always	Led first colour XY = fixed	off / on
Blinking	Led first colour XY = status from bus	no / yes
Blinking period / type	Led first colour XY = status from bus, Blinking = yes	0,25 s on / 0,25 s off 0,25 s on / 0,75 s off 0,5 s on / 0,5 s off 0,75 s on / 0,25 s off 0,5 s on / 1,5 s off 1 s on / 1 s off 1,5 s on / 0,5 s off 1 s on / 3 s off 2 s on / 2 s off 3 s on / 1 s off
Signal from bus	Led first colour XY = status from bus	not inverted / inverted

Parameter name	Conditions	Values
Led second colour XY		fixed when contact close status from bus
	<i>X = 1, 2; Y= A, B</i>	
Off delay		00:00:02:00 [other values in the range 00:00:00:00 ... 01.49.13:50]
	<i>Value in hh:mm:ss:ff.</i>	
Always	Led second colour XY = fixed	off / on
Blinking	Led second colour XY = status from bus	no / yes
Blinking period / type	Led second colour XY = status from bus, Blinking = yes	0,25 s on / 0,25 s off 0,25 s on / 0,75 s off 0,5 s on / 0,5 s off 0,75 s on / 0,25 s off 0,5 s on / 1,5 s off 1 s on / 1 s off 1,5 s on / 0,5 s off 1 s on / 3 s off 2 s on / 2 s off 3 s on / 1 s off
Signal from bus	Led second colour XY = status from bus	not inverted / inverted
Technical alarm		disabled / enabled
	<i>It enables the communication object nr. 0 "Technical alarm" that allows to activate an alarm signal via a bus telegram. The flashing led indicates that the alarm condition is active.</i>	

Object name	Conditions	Dim.	Flags	DPT	Comm. Obj. No.
Technical alarm		1 Bit	C--W-	[1.005] alarm	0
Leds intensity percentage	Leds intensity from bus = yes	1 Bit	C--W-	[5.001] percentage	2
Rocker X- Led first colour A	Led first colour XA = status from bus	1 Bit	CRWTU-	[1.001] switch	6 (X = 1) 10 (X = 2)
Rocker X- Led second colour A	Led second colour XA = status from bus	1 Bit	CRWTU-	[1.001] switch	7 (X = 1) 11 (X = 2)
Rocker X- Led first colour B	Led first colour XB = status from bus	1 Bit	CRWTU-	[1.001] switch	8 (X = 1) 12 (X = 2)
Rocker X- Led second colour B	Led second colour LED XB = status from bus	1 Bit	CRWTU-	[1.001] switch	9 (X = 1) 13 (X = 2)

7.8 Temperature control

The **Temperature control** folder includes the following secondary folders:

- Settings
- Heating
- Cooling
- Ventilation
- Scenes

The **Cooling** and **Ventilation** secondary folders appear only if in the **Settings** folder the parameter Thermostat function is set to the value *both heating and cooling* or *cooling*.

The **Scenes** secondary folder appears only if in the **Settings** secondary folder the parameter Scenes is set to the value *enabled*.

7.8.1 Settings

The **Settings** folder includes the following parameters:

- Thermostat function
- Command Communication Object
- Heating – cooling switchover
- Setpoint Cyclic sending interval
- Max manual temperature change
- Saving timeout (manual change)
- End of manual operation
- Max setpoint temperature change
- Scenes
- Valve protection function
- Frequency
- Time interval

7.8.1.1 Parameters and communication objects

Parameter name	Conditions	Values
Thermostat function		heating cooling both heating and cooling
Command Communication Object	Thermostat function = both heating and cooling	separated / unique
Heating – cooling switchover	Thermostat function = both heating and cooling	manual from bus automatic
Heating-cooling switchover cyclic sending interval	Thermostat function = both heating and cooling	no sending [other values in the range 30 s ... 120 min]

Parameter name	Conditions	Values
Setpoint cyclic sending interval		no sending [other values in the range 30 s ... 120 min]
	<i>The setpoint value that can be sent cyclically is the actual one, depending on the operating mode set manually by the user or automatically by another KNX supervising device with the possibility of time scheduling. The actual setpoint value takes also into account the actual state of the contacts window and presence detection (if the corresponding functions are enabled).</i>	
Max manual temperature change		not allowed, $\pm 1^{\circ}\text{C}$, $\pm 2^{\circ}\text{C}$, $\pm 3^{\circ}\text{C}$, $\pm 4^{\circ}\text{C}$, $\pm 5^{\circ}\text{C}$, $\pm 6^{\circ}\text{C}$, $\pm 7^{\circ}\text{C}$, $\pm 8^{\circ}\text{C}$, $\pm 9^{\circ}\text{C}$, $\pm 10^{\circ}\text{C}$
	<i>It defines the maximum range allowed for the manual change of the temperature value.</i>	
Saving timeout (manual change)		6 s [other values in the range 2s ... 12 s]
	<i>It defines the time interval to wait for a confirmation of a manual change (see previous parameter). If the time interval elapses without confirmation, the device automatically returns to the previous state without saving the change.</i>	
End of manual operation	General \Rightarrow Device operation as = stand-alone	till first telegram from bus [other values in the range 30 min ... 48 h]
Max setpoint temperature change		not allowed, $\pm 1^{\circ}\text{C}$, $\pm 2^{\circ}\text{C}$, $\pm 3^{\circ}\text{C}$, $\pm 4^{\circ}\text{C}$, $\pm 5^{\circ}\text{C}$, $\pm 6^{\circ}\text{C}$, $\pm 7^{\circ}\text{C}$, $\pm 8^{\circ}\text{C}$, $\pm 9^{\circ}\text{C}$, $\pm 10^{\circ}\text{C}$
	<i>It defines the maximum time allowed for changing the values of temperature setpoint in the several operating modes.</i>	
Scenes		disabled / enabled
Valve protection function		disabled / enabled
	<i>It enables the function that activates the drive for the valve control during periods of inactivity of the system.</i>	
Frequency	Valve protection function = enabled	once a day once a week once a month
Time interval	Valve protection function = enabled	10 s [other values in the range 5 s ... 20 min]

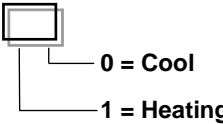
Nome oggetto	Conditions	Dim.	Flags	DPT	Comm. Obj. No.
Actual setpoint		2 Byte	CR-T--	[9.001] temperature ($^{\circ}\text{C}$)	52
Heating/cooling status out	Always visible	1 Bit	CR-T--	[1.100] heating/cooling	48
	<p>The communication object is updated on the bus on event of change internally elaborated by the controller. The object is always exposed and contains the information about the current conduction mode of the internal temperature controller.</p> <p>[1.100] DPT Heat/Cool 1 Bit</p> 				

Nome oggetto	Conditions	Dim.	Flags	DPT	Comm. Obj. No.
Heating/cooling status in	Thermostat function = both heating and cooling; Heating – cooling switchover = from bus	1 Bit	C-W---	[1.100] heating/cooling	49
<i>The communication object is received by the bus. All'evento di commutazione i regolatori interni degli stadi primario e ausiliario (se abilitato) commutano il modo di conduzione. Il modo di conduzione attivo è segnalato dall'apposito simbolo sul display.</i>					
HVAC mode in		1 Byte	C-W---	[20.102] HVAC mode	50
<i>The device receives the operating mode (HVAC mode) from a bus device with function of supervisor. The operating mode received through this communication object can be later modified by the user (in questo caso il termostato ambiente passa in controllo manuale).</i>					
HVAC forced mode in		1 Byte	C-W---	[20.102] HVAC mode	51
<i>The communication object allows to receive the operating mode similarly to what happens with the communication object HVAC mode; the difference is that the operating mode is received via this object (with the exception of the AUTO command) can not be subsequently modified by the user. The user can change the mode only after the forced HVAC mode has sent the AUTO command.</i>					
HVAC mode out		1 Byte	CR-T--	[20.102] HVAC mode	83
Building protection HVAC mode active		1 Bit	CR-T--	[1.11] DPT_State	101
HVAC manual mode	General ⇒ Device operation as = stand-alone/chrono	1 Byte	C-WTU-	[20.102] HVAC mode	53
Chrono active status	General ⇒ Device operation as = stand-alone/chrono	1 Bit	CR-T--	[1.011] state	54
Manual setpoint		2 Byte	C-W---	[9.001] temperature (°C)	55
Manual/forced setpoint active status		1 Bit	CRWTU-	[1.011] state	56

About the heating/cooling terminals

The application functions of the room temperature controller configurable with ETS are particularly suitable for the control through general-purpose or dedicated KNX actuators of the following heating/cooling terminals:

- radiators;
- electrical heaters;
- fancoils;
- radiant panels;
- dehumidification units;
- radiant panels + radiators (as auxiliary system);
- radiant panels + fancoils (as auxiliary system);
- radiant panels + dehumidification units.

7.8.1.2 Heating/cooling switchover

The switchover between the two seasonal modes (heating / cooling) may happen as follows:

- 1) manually on the device by the end user;
- 2) automatically by the device;
- 3) from the KNX bus through a dedicated communication object.

Manual switch-over (mode 1)

The manual switch-over is suitable for bus systems with one or a limited number of room temperature controllers. If the devices have been configured for this purpose, the user does the switch-over manually on the device (that acts as a "master" for the switch-over function); the device sends on the bus the output communication object [DPT 1.100 heat/cool] that switches possibly other room temperature controllers ("slave" devices) connected through a dedicated group address.

Automatic switch-over (mode 2)

The automatic switch-over is suitable for a 4-pipe hydraulic configuration of the heating/cooling installation (used e.g. for fan-coil units or ceiling radiant panels). Also in this case the information can be sent on the bus with the output communication object [DPT 1.100 heat/cool]; the difference from the first mode is that switching is performed automatically on the basis of a comparison between the values of the actual temperature and the setpoint temperature. In this mode, the manual switching by the user is disabled.

The automatic switch-over is realised with the introduction of a neutral zone according to the scheme in the picture below.

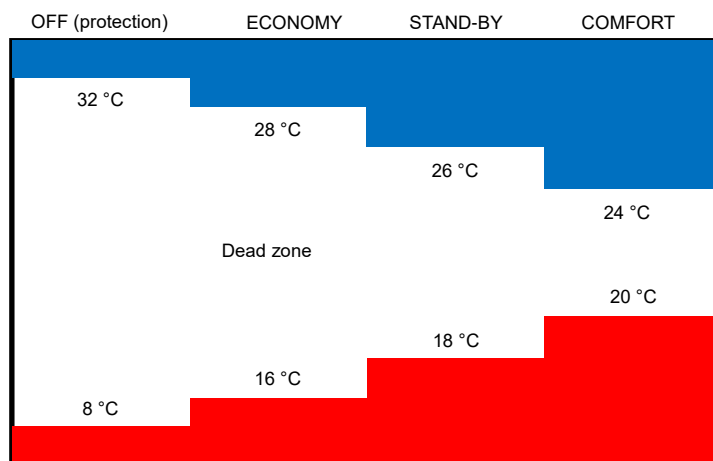

Neutral zone and example of setpoint values correctly distributed

Until the actual (measured) temperature is located below the setpoint value for the heating, the operation is heating; in the same way, if the actual value (measured) is greater than the setpoint value for the cooling, the mode is cooling. If the actual value (measured) temperature is within the dead zone, the previous mode of operation remains active; the switching point of the operation mode for heating / cooling must take place in correspondence with the current setpoint for the active HVAC, in the same way the switching cooling / heating must take place at the setpoint for heating.

Switch-over via KNX bus (mode 3)

The switch-over from the bus requires that the command is received from another KNX device, e.g. another room temperature controller or a Touch&See unit configured to this purpose. The other device works in this way as a “supervisor” device: the switch-over is triggered by the input communication object [DPT 1.100 heat/cool]. In this mode the manual switch-over by an enduser is disabled. Thanks to this mode, the supervising device is able to control the “slave” devices with time-scheduled programs, extending their functionality to that of a chronothermostat (centrally controlled by the supervising device).

The communication objects indicated in the block diagram allows monitoring and modifying the current conduction mode forced on the temperature controller. The object 48 – *Heating/cooling status out* is always exposed, even when the thermostat function is set on heating or cooling only. When the function is set on both heating and cooling, the cyclic sending on bus can be enabled; anyway, the information about the actual conduction mode can be acquired with a reading request to this communication object.

The object 49 – *Heating/cooling status in* is exposed only when the function is both heating and cooling and the switching among the different modes is performed by the bus.

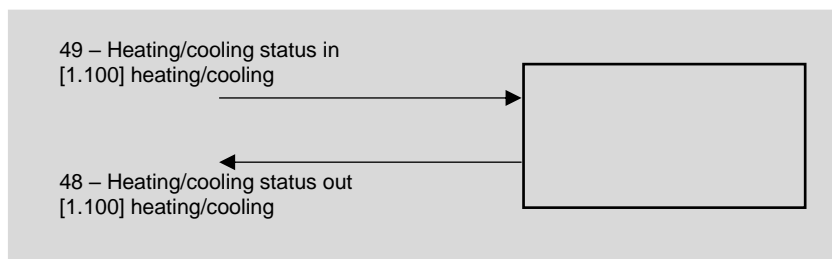

7.8.1.3 Valve protection function

The function is suitable for heating and cooling systems that use water as thermal conveying fluid and are provided with motorized valves for the interception of a zone or of a single room. Long periods of inactivity of the system can lead to the blockage of valves: to prevent this, the room temperature controller may periodically send a command to open / close the valve in the period of inactivity of the system. This possibility is made available in the application program by means of the parameter "Valve protection function", further defined by the frequency and duration of the valve control.

7.8.1.4 Remote Setpoint modification

The communication objects shown in figure allow to monitor the Setpoint forced modifications performed locally by the user when interacting with the LCD display and the touch buttons of the room thermostat. The

communication objects (from now on: C.O.) also allow to perform the same modifications remotely, for example from a supervisor software.

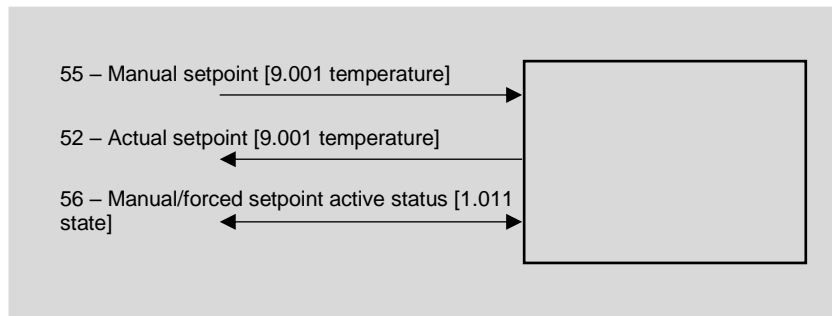

Those objects are about the Setpoint forced modification (symbol M on the LCD display): alternatively, the supervisor can act directly on the operating mode setpoints (C.O. with index 57-64). The value of the C.O. 52 - *Actual setpoint* represents the current operative setpoint which the control algorithms are based on. The C.O. 56 - *Manual/forced setpoint active status* indicates (read request mode) if the forced mode is active (symbol M on the LCD display present). The supervisor can force at any time the actual setpoint by writing a new value directly into the C.O. 55 - *Manual setpoint*. The C.O. 56 - *Manual/forced setpoint active status* can also be used in writing to exit the active forced mode.

7.8.1.5 Remote operative mode modification

The communication objects shown in figure allow to monitor the operating mode (comfort, standby, economy and building protection) modifications performed locally by the user when interacting with the LCD display and the touch buttons of the room thermostat, or the operating mode forced by chrono program. The communication objects (from now on: C.O.) also allow to perform the same modifications remotely, for example from a supervisor software.

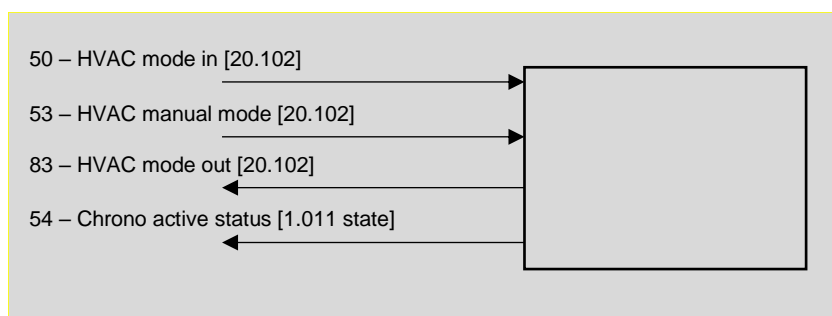

The C.O. 50 - *HVAC mode in* is associated to the chrono program. The C.O.s 83 - *HVAC mode out* and 54 - *HVAC chrono active status* allow the remote supervisor to discern the operating mode currently active on the room thermostat and also allow to understand if the chrono program is active or if attenuation is handled manually or not. The supervisor can set at any time a manual operating mode through C.O. 53 - *HVAC manual mode*; to start the chrono program remotely, the C.O. 53 - *HVAC manual mode* is to be set on value 0 = Automatic.



The communication objects *53 – HVAC manual mode* and *54 – HVAC chrono active status* are available only if the room thermostat has the parameter *Device operation* as in the *General* folder set as *stand-alone/chrono*.

7.8.2 Heating

The **Heating** folder includes the following parameters:

- Comfort temp. setpoint [°C]
- Standby temperature setpoint [°C]
- Economy temp. setpoint [°C]
- Building protection temp. setpoint [°C]
- Heating type
- Control type
- Hysteresis
- Cyclic sending interval
- Min. change of value to send [%]
- PWM cycle time
- Proportional band [0,1 K]
- Integral time [min]
- Floor temperature limitation
- Temperature limit [°C]
- Hysteresis [K]
- Auxiliary heating
- Communication object
- Disabled from bus
- Offset from setpoint
- Hysteresis
- Cyclic sending interval
- Ventilation for auxiliary heating

7.8.2.1 Parameters and communication objects

Conditions: *Settings* ⇒ Thermostat function = heating or both heating and cooling.

Parameter name	Conditions	Values
Comfort temp. setpoint [°C]		21 [range 10 ... 50]
Standby temperature setpoint [°C]		18 [range 10 ... 50]
	<i>For a correct operation of the device the standby temperature setpoint has to be < comfort temperature setpoint.</i>	
Economy temp. setpoint [°C]		16 [range 10 ... 50]
	<i>For a correct operation of the device the economy temperature setpoint has to be < standby temperature setpoint.</i>	
Building protection temp. setpoint [°C]		7 [range 2 ... 10]

Parameter name	Conditions	Values
Heating type		radiators electric fan-coils floor radiant panels ceiling radiant panels
	<i>It defines the terminal used for the thermal exchange in the room. The choice affects the parameters of the PWM control algorithm (Proportional band and Integral time) and the control options.</i>	
Control type		2 point hysteresis PWM (pulse width modulation) continuous
Hysteresis	Control type = 2 point hysteresis	0,3 K [other values in the range 0,2 K ... 3 K]
Cyclic sending interval	Control type = 2 point hysteresis, continuous	no sending [other values in the range 30 s ... 120 min]
Min. change of value to send [%]	Control type = continuous	10 [range 0 ... 100]
PWM cycle time	Control type = PWM	15 min [range 5 ... 240 min]
Proportional band [0,1 K]	Control type = continuous or PWM	* [range 0 ... 255]
	The value is in tenths of Kelvin (K) degree. *) The field contains a preset value that depend on the selected heating type (the value can be modified): <ul style="list-style-type: none"> • radiators: 50 (5 K) • electric: 40 (4 K) • fan-coils: 40 (4 K) • floor radiant panels: 50 (5 K) • ceiling radiant panels: 50 (5 K) The value of the parameter Proportional band represents the max difference between the setpoint temperature and the measured temperature that causes the max control output.	
Integral time [min]	Control type = continuous or PWM	* [other values in the range 0 ... 255 min]
	*) The field contains a preset value that depend on the selected heating type (the value can be modified): <ul style="list-style-type: none"> • radiators: 150 min • electric: 100 min • fan-coils: 90 min • floor radiant panels: 240 min • ceiling radiant panels: 180 min 	

Parameter name	Conditions	Values
Floor temperature limitation	Heating type = floor radiant panels, Inputs ⇒ Input 1 or Input 2 = [AI] floor surface temperature sensor or External sensors ⇒ Floor surface temperature sensor = enabled	disabled / enabled
	<p><i>Il parametro abilita la funzione di limitazione della temperatura superficiale di un pavimento riscaldante. Per la funzione è indispensabile misurare la temperatura superficiale del pavimento mediante l'abilitazione del sensore di temperatura corrispondente nella scheda Sensori esterni (dal bus) o nella scheda Ingressi.</i></p> <p>Important! This function does not replace the overtemperature protection usually installed in hydronic floor systems, realized with a dedicated safety thermostat.</p>	
Temperature limit [°C]	Floor temperature limitation = enabled	29 [range 20 ... 40]
	<p>According to EN 1264 a maximum allowed temperature is prescribed for the surface of a floor heating system:</p> <ul style="list-style-type: none"> • $T(\text{sup}) \text{ max} \leq 29^{\circ}\text{C}$ per le zone di normale occupazione; • $T(\text{sup}) \text{ max} \leq 35^{\circ}\text{C}$ per le zone periferiche degli ambienti. <p>National standard may limit those temperatures to lower values. Per zone periferiche si intendono fasce situate generalmente lungo i muri dell'ambiente rivolti verso l'esterno dell'edificio con larghezza massima di 1 m.</p>	
Hysteresis [K]	Floor temperature limitation = enabled	0,3 K [other values in the range 0,2 K ... 3 K]
	<p>Before quitting from the alarm status, the device waits until the surface temperature decreases under the threshold set offset pari al valore di isteresi.</p>	
Auxiliary heating		disabled / enabled
Communication object	Auxiliary heating = enabled	separated unique
Disabled from bus	Auxiliary heating = enabled	no / yes
	<p>It enables the activation and deactivation of the function through a telegram sent on the bus by a supervising device.</p>	
Offset from setpoint	Auxiliary heating = enabled	0,6 K [other values in the range 0 ... 3 K]
Hysteresis	Auxiliary heating = enabled	0,3 K [other values in the range 0,2 K ... 3 K]
Cyclic sending interval	Auxiliary heating = enabled	no sending [other values in the range 30 s ... 120 min]
Ventilation for auxiliary heating	Heating type = floor radiant panels or ceiling radiant panels	disabled / enabled
	<p>This option allows matching a system with high inertia as the floor radiant panels (hydronic version) to a system with low inertia as the fan-coils.</p>	

Object name	Conditions	Dim.	Flags	DPT	Comm. Obj. No.
Comfort setpoint (heating)		2 Byte	CRWTU-	[9.001] temperature (°C)	57
Standby setpoint (heating)		2 Byte	CRWTU-	[9.001] temperature (°C)	59

Object name	Conditions	Dim.	Flags	DPT	Comm. Obj. No.
Economy setpoint (heating)		2 Byte	CRWTU-	[9.001] temperature (°C)	61
Building protection setpoint (heating)		2 Byte	CRWTU-	[9.001] temperature (°C)	63
Heating out command	Control type = 2 points hysteresis or PWM	1 Bit	CR-T--	[1.001] switch	65
Heating and cooling out command	Control type = continuous	1 Bit	CR-T--	[1.001] switch	65
Heating and cooling out command	Control type = continuous	1 Byte	CR-T--	[5.001] percentage (0..100%)	65
Auxiliary heating output command	Auxiliary heating = enabled	1 Bit	CR-T--	[1.001] switch	67
Auxiliary heating disable	Auxiliary heating = enabled, Disabled from bus = yes	1 Bit	C-W---	[1.003] enable	69

About the floor temperature limitation function

The floor heating system (warm water version) provides plastic pipes embedded in the concrete layer or placed directly under the final coating of the floor (light or "dry" system) filled by heated water. The water releases heat to the final coating that heats the room by radiation. The standard EN 1264 Floor heating (Part 3: Systems and components - Dimensioning) prescribes a maximum allowed temperature (T_{Smax}) for the surface of the floor that is physiologically correct defined as:

- $T_{Smax} \leq 29^{\circ}\text{C}$ for zones of normal occupancy;
- $T_{Smax} \leq 35^{\circ}\text{C}$ for peripheral zones of the rooms.

National standards may also limit these temperatures at lower values. Peripheral zones are strips generally located along the external walls with a maximum width of 1 m.

The floor heating system (electrically powered version) involves the laying under the floor coating of an electric cable powered by the mains voltage (230 V) or low voltage (for example 12 or 45 V), possibly already prepared in the form of rolls with constant distance between sections of cable. The powered cable releases heat to the overlying coating that heats the room by radiation. The regulation is based on measurement of the temperature of the air mass, but generally requires the monitoring and limiting of the surface temperature by using a NTC-type sensor which is in contact with the floor surface.

The surface temperature limitation may be realized for several purposes:

- physiological compatibility (correct temperature at the height of the legs);
- when the system is used as auxiliary stage for heating. In this case, the heat losses to the exterior of the building are handled by the main heating stage, while the auxiliary stage only works to keep the floor temperature at a comfortable level (for example in bathrooms of residential buildings, sports centers, spas and thermal baths, etc.);
- protection against damages of the final coating due to an accidental overheating. Note that the warm water radiant panels are usually already equipped with a safety thermostat (with intervention

on the hydraulic mixing group), while in the case of electrical power this device is not usable and it is common practice to realize a temperature limitation with a surface temperature sensor connected to the device.

7.8.3 Cooling

The **Cooling** folder includes the following parameters:

- Comfort temp. setpoint [°C]
- Standby temperature setpoint [°C]
- Economy temp. setpoint [°C]
- Building protection temp. setpoint [°C]
- Cooling type
- Control type
- Hysteresis
- Cyclic sending interval
- Min. change of value to send [%]
- PWM cycle time
- Proportional band [0,1 K]
- Integral time [min]
- Anticondensation with probe
- Active anticondensation
- Flow temperature (project)
- Anticondensation hysteresis range
- Auxiliary cooling
- Disabled from bus
- Offset from setpoint
- Hysteresis
- Cyclic sending interval
- Ventilation for auxiliary cooling

Conditions: Temperature control ⇒ Settings ⇒ Thermostat function = cooling or both heating and cooling.

7.8.3.1 Parameters and communication objects

Parameter name	Conditions	Values
Comfort temp. setpoint [°C]		23 [range 10 ... 50]
Standby temperature setpoint [°C]		26 [range 10 ... 50]
	<i>For a correct operation of the device the standby temperature setpoint has to be > comfort temperature setpoint.</i>	
Economy temp. setpoint [°C]		28 [range 10 ... 50]
	<i>For a correct operation of the device the standby temperature setpoint has to be > economy temperature setpoint.</i>	
Building protection temp. setpoint [°C]		36 [range 30 ... 50]
Cooling type		fan-coils floor radiant panels ceiling radiant panels
	<i>If in Settings the parameter Thermostat function = both heating and cooling and Command communication object = unique, the parameter Cooling type is bound to the choice done for Heating.</i>	

Parameter name	Conditions	Values
Control type	Command communication object = separated	2 point hysteresis PWM (pulse width modulation) continuous
<i>If in Settings the parameter Thermostat function = both heating and cooling and Command communication object = unique, the parameter Control type is bound to the choice done for Heating.</i>		
Hysteresis	Control type = 2 point hysteresis	0,3 K [other values in the range 0,2 K ... 3 K]
Cyclic sending interval	Control type = 2 point hysteresis or continuous	no sending [other values in the range 30 s ... 120 min]
Min. change of value to send [%]	Control type = continuous	10 [range 0 ... 100]
PWM cycle time	Control type = PWM (puls width modulation)	15 min [range 5 ... 240 min]
Proportional band [0,1 K]	Control type = continuous or PWM	*
<p>The value is in tenths of Kelvin (K) degree.</p> <p>*) The field contains a preset value that depend on the selected cooling type (the value can be modified):</p> <ul style="list-style-type: none"> • fan-coils: 40 (4 K) • floor radiant panels: 50 (5 K) • ceiling radiant panels: 50 (5 K) <p>The value of the parameter Proportional band represents the max difference between the setpoint temperature and the measured temperature that causes the max control output.</p>		
Integral time [min]	Control type = continuous or PWM	*
<p>*) The field contains a preset value that depend on the selected cooling type (the value can be modified):</p> <ul style="list-style-type: none"> • fan-coils: 90 min • floor radiant panels: 240 min • ceiling radiant panels: 180 min 		
Anticondensation with probe	Cooling type = floor radiant panels or ceiling radiant panels, Inputs ⇒ Input 1 or Input 2 = [DI] anticondensation sensor or External sensors (from bus) ⇒ Anticondensation = enabled	disabled / enabled
Active anticondensation	Cooling type = floor radiant panels or ceiling radiant panels, External sensors (from bus) ⇒ Flow temperature = disabled	disabled enabled (project temperature)
	Cooling type = floor radiant panels or ceiling radiant panels, External sensors (from bus) ⇒ Flow temperature = enabled	disabled enabled (flow and dew point temperature comparison)
<i>If the flow temperature (either measured by a sensor or project value) is lower than the calculated dew-point temperature, the seasonal mode is cooling and the device is calling, the valve is closed and an alarm condition is reported on the display.</i>		

Parameter name	Conditions	Values
Flow temperature (project)	Cooling type = floor radiant panels or ceiling radiant panels, External sensors (from bus) ⇒ Flow temperature = disabled	14°C [other values in the range 14,5°C ... 20°C]
	<i>It appears only if the flow temperature of an external sensor (from bus) is not available.</i>	
Anticondensation hysteresis range	Cooling type = floor radiant panels or ceiling radiant panels, External sensors (from bus) ⇒ Flow temperature = enabled	0,5 K [other values in the range 0,2 K ... 3 K]
	<i>Before exiting the alarm condition, it is waited until the Dew Point is greater than the calculated value of the flow temperature of an offset equal to the hysteresis value.</i>	
Auxiliary cooling		disabled / enabled
Disabled from bus	Auxiliary cooling = enabled	no / yes
	<i>This parameter enables the activation and deactivation of the function through a telegram from a bus device with supervising function.</i>	
Offset from setpoint	Auxiliary cooling = enabled	0,2 K / 0,3 K / 0,4 K / 0,5 / 0,6 K 0,8 K / 1 K / 1,5 K / 2 K / 2,5 K / 3 K
Hysteresis	Auxiliary cooling = enabled	0,2 K / 0,3 K / 0,4 K / 0,5 / 0,6 K 0,8 K / 1 K / 1,5 K / 2 K / 2,5 K / 3 K
Cyclic sending interval	Auxiliary cooling = enabled	hh:mm:ss (00:00:00)
	<i>00:00:00 means that the cyclic sending is not enabled.</i>	
Ventilation for auxiliary cooling	Cooling type = floor radiant panels or ceiling radiant panels	disabled / enabled
	<i>This option allows combining a high-inertial system as the floor radiant panels to a low-inertial one as the fan-coils.</i>	

Object name	Conditions	Dim.	Flags	DPT	Comm. Obj. No.
Comfort setpoint (cooling)		2 Byte	CRWTU-	[9.001] temperature (°C)	58
Standby setpoint (cooling)		2 Byte	CRWTU-	[9.001] temperature (°C)	60
Economy setpoint (cooling)		2 Byte	CRWTU-	[9.001] temperature (°C)	62
Building protection setpoint (cooling)		2 Byte	CRWTU-	[9.001] temperature (°C)	64
Cooling out command	Control type = 2 point hysteresis or PWM	1 Bit	CR-T--	[1.001] switch	66
Cooling out command	Control type = continuous	1 Byte	CR-T--	[5.001] percentage (0..100%)	66
Auxiliary cooling output command	Auxiliary cooling = enabled	1 Bit	CR-T--	[1.001] switch	68

Object name	Conditions	Dim.	Flags	DPT	Comm. Obj. No.
Auxiliary cooling disable	Auxiliary cooling = enabled, Disabled from bus = yes	1 Bit	C-W---	[1.003] enable	70
Anticondensation alarm	At least one anticondensation protection enabled	1 Bit	CR-T--	[1.005] alarm	92

About the anticondensation protection function

The objective of this function is to prevent the condensation on the thermal exchange surfaces of the installation or building when cooling is working. This function is mainly used in systems with thermal exchange consisting in surface terminals such as for the floor and ceiling cooling radiant systems. In this case the hydraulic circuits contain refrigerated water; usually the latent loads (due to the increase of air humidity in the room) are handled by air-conditioning units and the temperature and humidity conditions are far from those that could cause condensation. If this is not done in a satisfactory manner, or in case of stop of the air-conditioning units, it is necessary to provide additional safety measures to prevent or restrict the accidental formation of condensation on cold surfaces.

From a general point of view, the anti-condensation protection can be realized:

- by installing in the room an anticondensation sensor; when this detects condensation, it closes the hydraulic circuit of the room. This is a protection of the *passive type*, i.e. a reaction occurs when the formation of condensation has already started;
- by calculating the dew-point temperature and comparing it with the conveying fluid temperature. If the comparison indicates that critical conditions for the formation of condensation are approaching, the hydraulic circuit is closed and / or the temperature of the conveying fluid is modified. This is a protection of the *active type*, i.e. the action is intended to prevent the formation of condensation.

Nr.	Type	Denominazione	Description
1a	Passive	Anticondensation protection with sensor (connected to a physical input of the device)	Hardware protection that closes the cooling circuit of the room or zone when condensation is detected by a sensor connected to an input of the room temperature controller (configured as digital). To this purpose the communication object 164: Auxiliary cooling output command [DPT 1.001 switch] is used.
1b	Passive	Anticondensation protection with sensor (via bus)	As 1a, but the room temperature controller receives the information of condensation via bus from another KNX device through the communication object 146: Anticondensation (from bus) [DPT 1.001 switch].
2a	Active	Anticondensation protection with comparison between T_{flow} (project value, set as parameter in ETS) and $T_{dewpoint}$ (calculated by the room temperature controller)	Software protection that closes the cooling circuit of the room or zone when the flow temperature defined in the project of the cooling system (set in the corresponding parameter of ETS) is lower than the dew-point temperature calculated by the room temperature controller with the temperature and relative humidity values of the air mass in the room. o this purpose the communication object 164: Auxiliary cooling output command [DPT 1.001 switch] is used.
2b	Active	Anticondensation protection with comparison between T_{flow} (value measured and sent on the bus) and $T_{dewpoint}$ (calculated by the room temperature controller)	Software protection that closes the cooling circuit (measured) and received via bus from another KNX device is lower than the dew-point temperature calculated by the room temperature controller with the temperature and relative humidity values of the air mass in the room. The communication objects 142 in input: TFlow temperature (from bus) [DPT 9.001 temperature °C] and 164: Auxiliary cooling output command [DPT 1.001 switch] are used.

3	Active	Anticondensation protection with sending on the bus the dew-point temperature and changing of the flow temperature	Software protection that provides for the sending on the bus of the dew point calculated by the room temperature controller using the temperature and relative humidity values of the air mass of the room to a KNX device able of controlling the mixing of the conveying fluid to be sent to the cooling circuits. The intervention on the adjustment device is done by the KNX device that receives the dew point temperature sent by the room temperature controller. The communication object used is the 175: Dew Point [DPT 9001 ° C temperatures].
---	--------	--	--

Anticondensation protections that can be realized

If an anticondensation sensor is used, it is necessary use a device provided with a potential-free signalling contact. Si può prevedere:

- il collegamento del contatto di segnalazione to an input of the room temperature controller configured as digital (Inputs \Rightarrow Input 1 or Input 2 = [DI] anticondensation sensor). The signal coming from the sensor is received and processed directly by the room temperature controller (case 1a of the table);
- il collegamento del contatto di segnalazione to an input channel of another KNX device, e.g. a pushbutton interface or a binary input (External sensors (from bus) \Rightarrow Anticondensation sensor = enabled). In this case the signal of the sensor is transmitted to the room temperature controller through the status of a communication object (case 1b of the table).

If the comparison between the calculated dew-point temperature and the conveying fluid flow temperature is used, there are three possibilities:

- if the flow temperature is not available (case 2a of the table), for the comparison you can enter in the parameter *Flow temperature (project)* the value used in the project of the cooling system;
- if the flow temperature is available (case 2b of the table), for the comparison the parameter *Active anticondensation* al valore abilitato;
- if it is available a bus actuator able to control a mixing group for the conveying fluid, the room temperature controller sends the calculated dew-point temperature value on the bus; the actuator confronts that value with the flow temperature and possibly change the mixing conditions so that the temperature and humidity conditions are far from those that can cause condensation.

The kind of anti-condensation protection to be done must be evaluated at the planning stage of the heating system and depends on factors such as the building type, the continuity of service and the comfort level to be offered, the available KNX devices, etc.

7.8.4 Main and auxiliary ventilation

The **Ventilation** folder includes the following parameters:

- Control type
- Threshold first speed [0,1 K]
- Threshold second speed [0,1 K]
- Threshold third speed [0,1 K]
- Speed control hysteresis [K]
- Proportional band [0,1 K]
- Minimo cambiamento valore da inviare [%]
- Manual operation
- Hot start
- Min. temp.to start ventilation [°C]
- Antistratification function
- Antistratification temp. differential
- Hysteresis
- Disable ventilation from bus
- Signal from bus
- Fan start delay
- Fan stop delay

The conditions for the appearance of the **Ventilation** folder are:

Heating ⇒ Type of heating = fan-coils or Type of cooling = fan-coils

or a combination of the two conditions:

Heating ⇒ Type of heating = floor radiant panels or ceiling radiant panels and **Heating** ⇒ Ventilation ⇒ Auxiliary heating = enabled

Cooling ⇒ Type of cooling = floor radiant panels or ceiling radiant panels and **Cooling** ⇒ Ventilation for auxiliary = enabled

This way two types of installations can be controlled: i) fan-coil terminals or ii) radiant panels as main stage and fan-coil terminals as auxiliary stage.

7.8.4.1 Parameters and communication objects

Parameter name	Conditions	Values
Control type		1 speed 2 speeds 3 speeds continuous regulation
Threshold first speed [0,1 K]		10 [range 0 ... 255]
	<i>The value is represented in tenths of Kelvin degrees. If the parameter Thermostat function = both heating and cooling, the threshold value is valid for both seasonal modes.</i>	
Threshold second speed [0,1 K]	Control type = 2 speeds	20 [range 0 ... 255]
	<i>The value is represented in tenths of Kelvin degrees. If the parameter Thermostat function = both heating and cooling, the threshold value is valid for both seasonal modes. For a correct operation of the ventilation, Threshold second speed > Threshold first speed.</i>	

Parameter name	Conditions	Values
Threshold third speed [0,1 K]	Control type = 3 speeds	30 [range 0 ... 255]
<p><i>The value is represented in tenths of Kelvin degrees. If the parameter Thermostat function = both heating and cooling, the threshold value is valid for both seasonal modes. For a correct operation of the ventilation, Threshold third speed > Threshold second speed.</i></p>		
Speed control hysteresis [K]	Control type = 1, 2 or 3 speeds	0,3 K [other values in the range 0,2 K ... 3 K]
Proportional band [0,1 K]	Control type = continuous regulation	30 [range 0 ... 255]
<p><i>The value is represented in tenths of Kelvin degrees. If the parameter Thermostat function = both heating and cooling, the threshold value is valid for both seasonal modes.</i></p>		
Min change of value to send [%]	Control type = continuous regulation	10 [range 2 ... 40]
Manual operation		not depending on the temperature depending on the temperature
<p><i>If the parameter = not depending on the temperature, the fan speed set by the user is not changed even when the temperature setpoint is reached; if the parameter = depending on the temperature, the fan stops when the temperature setpoint is reached.</i></p>		
Hot start	Thermostat function = both heating and cooling, Inputs ⇒ Input X ⇒ [AI] coil battery temperature sensor or External sensors (from bus) ⇒ coil temperature = enabled	no / yes
<p><i>For carrying out the function must be enabled a sensor for measuring the temperature of the heat exchanger of the fan coil. To this purpose either an input (configured as analog) or an external sensor (from bus) can be used.</i></p>		
Min. temp.to start ventilation [°C]	Hot start = yes	35 [range 28 ...40]
<p><i>If enabled, the function is active only in heating mode.</i></p>		
Antistratification function	Inputs ⇒ Input X = [AI] antistratification temperature sensor or External sensors (from bus) ⇒ Antistratification temperature = enabled	disabled / enabled
<p><i>For carrying out the function at least a sensor for measuring a second temperature value must be enabled at a different height than that of the room temperature controller. To this purpose either an input (configured as analog) or an external sensor (from bus) can be used.</i></p>		
Antistratification temp. differential	Antistratification function = enabled	2 [K/m] [other values in the range 0,25 ... 4,00 K/m]
<p><i>The DIN 1946 recommends a max temperature gradient of 2 K/m for rooms with standard height (between 2,70 and 3 m).</i></p>		

Parameter name	Conditions	Values
Hysteresis	Antistratification function = enabled	0,5 K [other values in the range 0,2 ... 3 K]
Disable ventilation from bus		no / yes
Signal from bus	Disable ventilation from bus = yes	not inverted inverted
Fan start delay		0 s [other values in the range 10 s ... 12 min]
	<i>It appears also if the hot-start function is active (through measuring of the conveying fluid temperature at the battery for the thermal exchange). The function is active in both seasonal modes (heating and cooling).</i>	
Fan stop delay		0 s [other values in the range 10 s ... 12 min]
	<i>The function allows prolonging the operation of the ventilator, dissipating in the room the residual heat or cool present in battery for the thermal exchange. The function is active in both seasonal modes (heating and cooling).</i>	

Object name	Conditions	Dim.	Flags	DPT	Comm. Obj. No.
Fan continuous speed	Control type = continuous regulation	1 Byte	CR-T--	[5.001] percentage (0..100%)	71
Fan speed 1	Control type = 1, 2 or 3 speeds	1 Bit	CR-T--	[1.001] switch	72
Fan speed 2	Control type = 2 or 3 speeds	1 Bit	CR-T--	[1.001] switch	73
Fan speed 3	Control type = 3 speeds	1 Bit	CR-T--	[1.001] switch	74
Fan control disable	Disable ventilation from bus = yes	1 Bit	C-W---	[1.002] boolean	75
Fan manual speed		1 Byte	CRWTU-	[5.010] counter pulses (0...255)	76
Fan speed status		1 Byte	CR-T--	[5.010] counter pulses (0...255)	77
Fan manual active status		1 Bit	CRWTU-	[1.011] state	78
Fan manual speed percentage		1 Byte	R-CT--	[5.1] DPT_Percentage	102
Fan manual speed off status		1 Bit	R-CT--	[1.11] DPT_State	103

7.8.4.2 Delayed fan start ("hot-start") function

This function is used in case the fan forces in the room air passing through a heat exchange coil (as in the case of the terminals to the fan-coil). In the heating mode of operation, to avoid possible discomfort caused by the dispatch of cold air in the room, the room temperature controller does not start the fan until the fluid has not reached a sufficiently high temperature. This situation normally occurs at the first start or after long periods of inactivity. The function can be carried out by:

- 1) a temperature control (through a temperature sensor on the coil exchange battery);
- 2) a delayed start (function approximated).

In the first case the temperature of the heat conveying fluid is acquired at the exchange battery. The function then has an effective temperature control, but for the execution is necessary that:

- the heat exchange coil is equipped with a sensor of minimum water temperature that acquires the temperature of the heat conveying fluid;
- the sensor is connected to an input of the room temperature controller (configured as analog) or to another KNX device with an analog input.

In the second case just sets a time delay starting from the flow request; there is no temperature control. The effectiveness of the function depends on a field measurement of the time actually required to have sufficiently warm air from the terminal.

7.8.4.3 Antistratification function

This function is used in the case of heating systems with thermal exchange of convective type for rooms with height and volume much higher than usual (atriums, fitness facility, commercial buildings, etc.). Because of the natural convection - with warm air rising to the highest altitudes of the room - the phenomenon of air stratification occurs, with energy waste and discomfort for the occupants at the same time. The function opposes to the air stratification, forcing the warm air downwards.

The antistratification function requires:

- rooms of great height;
- availability of ventilation devices able to force the air movement downwards (opposed to the natural convective movement of warm air);
- measuring of the temperature at two heights through the installation of a second temperature sensor at an adequate height in order to measure the actual air stratification (the main room temperature controller is supposed to be installed at 1.5 m).

For rooms with ordinary height (2,70÷3,00 m) the DIN 1946 standard recommends not to exceed 2 K/m in order to have an adequate comfort; this gradient may be bigger in higher rooms.

7.8.4.4 2-stage configuration with fan-coils as auxiliary stage

The fan-coil units may be used both as a main stage and secondary stage. As main stage they can be combined only to radiators as auxiliary stage. If, however, the main stage is done with (floor or ceiling) radiant panels, the fan-coils can be used as auxiliary stage. In the latter case they work in automatic mode with a configurable offset with respect to the temperature setpoint for the main stage, and then carry out their compensation function while the main stage is brought in temperature with bigger inertia.

The **Ventilation** folder, that is unique, configures a main or a auxiliary stage depending on the settings choosed in the **Heating** and **Cooling** folders. Similarly, the display interface will act on manual / automatic and manual forcing of the only fan-coil.

A particular case occurs when a fan-coil unit works in a season as auxiliary stage and in the other one as main stage. It is for example the case of:

- a radiant panels system that works only for heating and has a fan-coil as auxiliary stage; the same fan-coil works as main stage for cooling;
- a radiator system that has a fan-coil as auxiliary stage for heating; the same fan coil unit functions as main stage for cooling.

In these cases with the configuration adopted, the following steps are necessary:

1. Settings ⇒ Thermostat function = both heating and cooling. This configuration enables both folders (heating and cooling)
2. Heating ⇒ Heating type = floor radiant panels or ceiling radiant panels
3. Heating ⇒ Command communication object = separated (if unique is choosen, the parameter Cooling ⇒ Cooling type does not appear)
4. Heating ⇒ Auxiliary heating = enabled
5. Auxiliary heating ⇒ Communication object = separated
6. Heating ⇒ Ventilation for auxiliary heating = enabled
7. Cooling ⇒ Cooling type = fancoils

Important! If the fan-coil system has a 2-pipe hydraulic configuration, the objects 163 Auxiliary heating output command (1 bit) and 162 Cooling out command (1 byte) have to be set in logical OR in the actuator for controlling the fan-coil which in this case is unique.

An alternative solution that avoids the setting of a logic OR can be realized by configuring a main stage for heating and cooling with radiant panels through separate valves and an auxiliary stage for heating and cooling fan coil through combined valves. The offset of the auxialiary stage for cooling is set to the value 0 (zero); this corresponds to a configuration for main stage. The object Cooling out command (1 byte) is not connected, so that the radiant panel system works only for heating.

7.8.4.5 Remote fan speed modification

The communication objects shown in figure allow to monitor actual fan speed forced automatically (A) by the temperature controller or set locally by the user when interacting with the LCD display and the touch buttons of the room thermostat. The communication objects (from now on: C.O.) also allow to perform the same modifications remotely, for example from a supervisor software.

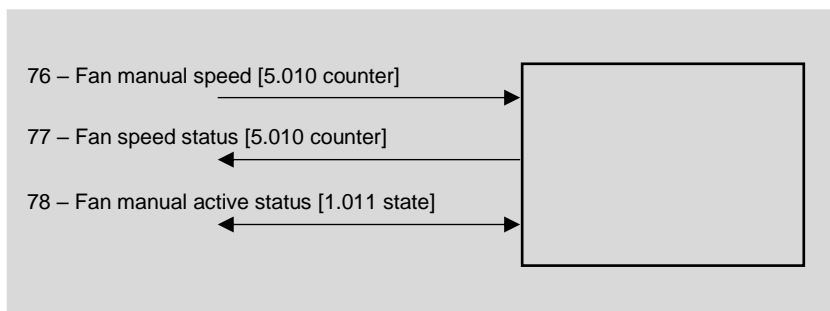

The C.O. 77 – *Fan manual status* allows to evaluate the actual fan speed; the C.O. 78 – *Fan manual active status* contains the information about automatic (=0, not active) or manual (=1, active) operating mode. By modifying the C.O. 76 – *Fan manual speed*, the fan automatically switches to the setpoint speed; to return to automatic mode (A), the supervisor must exit from manual mode by modifying the C.O. 78 – *Fan manual active status* (=0, not active).

Accepted values for C.O.s 76 and 77 depend on the number of speeds set in ETS.

If *Control Type* parameter in Ventilation folder is = 1, 2 or 3 speeds, C.O.s with DPT [5.010 counter] accept the following values:

- = 0: OFF
- = 1: speed 1
- = 2: speed 2 (if *Control Type* > 1 speed)
- = 3: speed 3 (if *Control Type* > 2 speed)

If *Control Type* parameter in Ventilation folder is = continuous regulation, the values of the C.O.s with DPT [5.010 counter] match the following percentage of the maximum speed:

- = 0: OFF
- = 1: 20%
- = 2: 40%
- = 3: 60%
- = 4: 80%
- = 5: 100%

7.8.5 Scenes

The folder allows the scenes configuration (up to 8), assigning to each one an identification number and the operating mode to be activated when recalled (e.g. with an ekinex pushbutton or another KNX device with this function). If *Learning mode = enabled*, receiving a telegram of scene storage determines the association of the scene to the operating mode currently set on the device.

Important! Be careful setting the *Download overwrite* parameter. The download of the application program, particularly after the first commissioning of the system, may cause the loss of the already stored scenes.

The **Scenes** folder includes the following parameters:

- Download overwrite
- Scene X
- Scene number
- HVAC mode
- Activation delay
- Learning mode

Condition: *Temperature control* ⇒ Settings ⇒ Scenes = enabled.

7.8.5.1 Parameters and communication objects

Parameter name	Conditions	Values
Download overwrite		disabled / enabled
	<p>If <i>Overwrite download = disabled</i>: at the download of the application on the device, the operating modes previously stored are not overwritten.</p> <p>If <i>Overwrite download = enabled</i>: at the download of the application on the device, the operating modes previously stored are reprogrammed with the values selected from the HVAC mode parameter.</p>	
Scene X		disabled / enabled
	This parameter enables the scene X (X = 1, 2, ... 8).	
Scene number	Scene X = enabled	1 [range 1 ... 64]
HVAC mode	Scene X = enabled	auto / comfort / standby / economy / building protection
	This parameter defines the operating mode of the scene X.	
Activation delay	Scene X = enabled	hh:mm:ss (00:00:00)
	Receiving a telegram that recalls a scene, once elapsed the time interval set in the Activation delay parameter, the programmed operating mode is activated.	
Learning mode	Scene X = enabled	disabled / enabled

Object name	Conditions	Dim.	Flags	DPT	Comm. Obj. No.								
HVAC scene number		1 Byte	C-W---	[17.001] scene number [18.001] scene control	79								
<p><i>It stores or recalls a scenario. The six least significant bits (0 to 5) in the byte of the code represent the number of the scene, while the most significant bit (7) is the operation code (1 = stores, 0 = recalls).</i></p> <div style="text-align: center;"> <p>1 Byte</p> <p>Bit number</p> <table border="1" style="margin: auto;"> <tr> <td style="padding: 2px 5px;">7</td> <td style="padding: 2px 5px;">6</td> <td style="padding: 2px 5px;">5</td> <td style="padding: 2px 5px;">4</td> <td style="padding: 2px 5px;">3</td> <td style="padding: 2px 5px;">2</td> <td style="padding: 2px 5px;">1</td> <td style="padding: 2px 5px;">0</td> </tr> </table> <div style="margin-top: 10px;"> <p>scene number (1-64) not used</p> <p>0 = recall, 1 = save</p> </div> </div>						7	6	5	4	3	2	1	0
7	6	5	4	3	2	1	0						

7.9 Relative humidity control

The **Relative humidity control** folder includes the following secondary folders:

- Dehumidification
- Humidification

The **Dehumidification** and **Humidification** secondary folders appear only if a relative humidity sensor is enabled. The acquisition of relative humidity of the room can be done in two ways:

- 1) through the integrated R.H. sensor;
- 2) via bus from a R.H. KNX sensor.

The sensor measures the humidity value of the air mass of the room that can be used for several purposes:

- local displaying and sending on the bus (information purposes) of the value through the DPT [9.007] percentage (%);
- use of the measured value for the calculation of psychrometric derived values on the bus and sending them through DPT;
- calculation of related indexes (perceived temperature) for local displaying or sending on the bus;
- use for room ventilation through fans, opening outlets to the outside, opening windows with motorized actuators. The control is done through threshold values;
- use to control the temperature and humidity conditions of comfort in cooling systems with radiant panels and integration for the treatment of latent heat (start of dedicated terminals without changing the flow temperature of the cooling water);
- use for safe control of radiant cooling panels, that do not have integration for the treatment of latent heat, by calculating the critical temperature and humidity conditions (dew-point) and changing the flow temperature of the cooling water.

7.9.1 Dehumidification

The **Dehumidification** secondary folder includes the following parameters:

- Dehumidification function
- Humidity setpoint [%]
- Humidity hysteresis
- Cyclic sending interval
- Enable dehumid. control from bus
- Signal from bus
- Subordinated to temperature control
- Integration
- Temperature difference for integration
- Hysteresis for integration

7.9.1.1 Parameters and communication objects

Parameter name	Conditions	Values
Dehumidification function		disabled heating only cooling only both heating and cooling
<i>This parameter enables selectively the dehumidification function.</i>		

Parameter name	Conditions	Values
Humidity setpoint [%]	Dehumidification function different than disabled	55 [range 30 ... 60]
Humidity hysteresis	Dehumidification function different than disabled	0,8 % [other values in the range 0,5... 4%]
Subordinated to temperature control		no / yes
	<i>Parameter only for cooling.</i>	
Dehumidification start delay	Subordinated to temperature control = no	00:05:00 hh:mm:ss [range 00:00:00 ... 18:12:15]
	<i>The value 00:00:00 means that the delay is not enabled.</i>	
Integration		no / yes
	<i>Parameter only for cooling.</i>	
Temperature difference for integration	Integration = yes	1,5°C [other values in the range 0,5 ... 3 °C]
	<i>Parameter only for cooling.</i>	
Hysteresis for integration	Integration = yes	0,5 K [other values in the range 0,2 K ... 3 K]
	<i>Parameter only for cooling.</i>	
Cyclic sending interval		no sending [other values in the range 30 s ... 120 min]
	<i>00:00:00 means that the Cyclic sending is not enabled.</i>	
Disable dehumid. control from bus		no / yes
Signal from bus	Enable dehumid. control from bus = yes	not inverted / inverted

Object name	Conditions	Dim.	Flags	DPT	Comm. Obj. No.
Dehumidification command		1 Bit	CR-T--	[1.001] switch	84
Dehumidification control disable		1 Bit	C-W---	[1.002] boolean	85
Dehumidification water battery command		1 Bit	C-W---	[1.001] switch	86
	<i>The object is enabled only if the system for temperature control is set to underfloor heating and cooling or ceiling system. Furthermore the dehumidification has to be set to only cooling.</i>				
Dehumidification integration control		1 Bit	CR-T--	[1.001] switch	87
	<i>The object is enabled only if the system for temperature control is set to underfloor heating and cooling or ceiling system. Furthermore the dehumidification has to be set to only cooling. The object becomes ON when at the same time the relative humidity measured exceeds the temperature setpoint and the room temperature exceeds the setpoint of the temperature difference to activate integration.</i>				
Relative humidity setpoint for dehumidification		2 Byte	RWCTU-	[9.007] humidity (%)	99
	<i>The object becomes ON when at the same time the relative humidity measured exceeds the temperature setpoint and the room temperature exceeds the setpoint of the temperature difference to activate integration.</i>				

7.9.2 Humidification

The **Humidification** secondary folder includes the following parameters:

- Humidification function
- Humidity setpoint [%]
- Humidity hysteresis [%]
- Cyclic sending interval
- Enable humidification from bus
- Signal from bus

7.9.2.1 Parameters and communication objects

Parameter name	Conditions	Values
Humidification function		disabled heating only cooling only both heating and cooling
<i>This parameter enables selectively the humidification function.</i>		
Humidity setpoint	Humidification different than disabled	35 [range 25 ... 45 %]
Humidity hysteresis		0,8 % [other values in the range 0,5 ... 4%]
Cyclic sending interval		no sending [other values in the range 30 s ... 120 min]
Disable humidification from bus		no / yes
Signal from bus	Enable humidification from bus = yes	not inverted / inverted

Object name	Conditions	Dim.	Flags	DPT	Comm. Obj. No.
Humidification command		1 Bit	CR-T--	[1.001] switch	88
Humidification control disable		1 Bit	C-W---	[1.002] boolean	89
Relative humidity setpoint for humidification		2 Byte	RWCTU-	[9.007] humidity (%)	100

7.10 Comfort

The **Comfort** folder includes the following secondary folders:

- Comfort area
- Calculated psychrometric values

The **Comfort area** and **Calculated psychrometric values** secondary folders appear only if a temperature sensor and a relative humidity sensor are enabled either in the Internal sensors folder or the External sensors (from bus) folder.

7.10.1 Comfort area

The **Comfort area** secondary folder includes the following parameters:

- Cyclic sending interval
- Minimum temperature [°C]
- Maximum temperature [°C]
- Minimum relative humidity [%]
- Maximum relative humidity [%]
- Max absolute humidity [g/kg x 0,1]

7.10.1.1 Parameters and communication objects

Parameter name	Conditions	Values
Cyclic sending interval		no sending [other values in the range 30 s ... 120 min]
Minimum temperature [°C]		20 [range 0 ... 50]
Maximum temperature [°C]		26 [range 0 ... 50]
Minimum relative humidity [%]		30 [range 0 ... 100]
Maximum relative humidity [%]		65 [range 0 ... 100]
Max absolute humidity [g/kg x 0,1]		115 [range 50... 200]

Object name	Conditions	Dim.	Flags	DPT	Comm. Obj. No.
Comfort state		1 Bit	CR-T--	[1.006] binary value	80
<p><i>Comfort state = 1: temperature and relative humidity are inside the defined comfort area.</i> <i>Comfort state = 0: temperature and relative humidity are outside the defined comfort area.</i></p>					

About the comfort area

You can check whether the temperature and relative humidity values measured in a room are in or out of an area of climatic comfort defined by the parameters of the dedicated folder and send the corresponding information on the bus. The area of comfort may be defined for example:

- according to the standard DIN 1946, without modifying the default values of the parameters proposed by the ETS application program for T(min), T(max), R.H.(min) e R.H.(max);
- customizing values of the parameters within the range allowed by the application program depending on the use of the building or rooms, the geographical area, the activities carried out by the occupants and other factors.

As default values of the area of comfort the following values are considered:

- standard maxtemperature 26 °C;
- standard mintemperature 20 °C;
- standard max relative humidity 65%;
- standard min relative humidity 30%.

The defined comfort area refers both to heating and cooling mode.

7.10.2 Calculated psychrometric values

The **Calculated psychrometric values** secondary folder includes the following parameters:

- Dew point temperature
- Cyclic sending interval
- Min. change of value to send [K]
- Temperature to send if no request [°C]
- Perceived temperature [°C]
- Cyclic sending interval
- Min. change of value to send [K]

Condition for displaying the folder: Internal sensors ⇒ Relative humidity sensor = enabled.

7.10.2.1 Parameters and communication objects

Parameter name	Conditions	Values
Dew point temperature		disabled / enabled
	<i>Sending on the bus the dew-point temperature value allows realizing an anticondensation active protection changing the temperature of the conveying fluid, if on the bus there is a device for the control of the mixing group. If the room temperature controller is installed in a room where there is no cooling (i.e. a bathroom), it is recommended to exclude the room from the control, setting the parameter to disabled.</i>	
Cyclic sending interval	Dew point temperature = enabled	no sending [other values in the range 30 s ... 120 min]
Min. change of value to send [K]	Dew point temperature = enabled, Cyclic sending interval different than no sending	0,2 K / no sending [other values in the range 0,2 ... 3 K]

Parameter name	Conditions	Values
Temperature to send if no request [°C]	Dew point temperature = enabled	0 [range -10 ... 10]
	<i>If the device is not calling (or the setpoint is not reached), sending a very low value (e.g. 0°C) to a device for the control of a mixing group, the value does not have any influence on the calculation of the max. dew-point temperature. This parameter allows to exclude a zone, if it is not calling conveying fluid.</i>	
Perceived temperature [°C]		disabled / enabled
	<i>The calculation of the value is made according to the Humidex index. The correlation is significative for temperatures between 20 and 55 °C.</i>	
Cyclic sending interval	Perceived temperature = enabled	no sending [other values in the range 30 s ... 120 min]
Min. change of value to send [K]	Perceived temperature = enabled, Cyclic sending interval different than no sending	0,2 K / no sending [other values in the range 0,2 ... 3 K]

Object name	Conditions	Dim.	Flags	DPT	Comm. Obj. No.
Dew point temperature	Dew point temperature = enabled	2 Byte	CR-T--	[9.001] temperature °C	81
Perceived temperature	Perceived temperature = enabled	2 Byte	CR-T--	[9.001] temperature °C	82

About the perceived temperature

The combined measuring of relative humidity and temperature in the room allows to calculate the perceived temperature which is an index of the condition of discomfort climate applicable to the summer season. The calculated value can be displayed on the thermostat (if enabled) and /or be sent on the KNX bus for displaying on other bus devices (e.g. a control and display Touch &See unit). The criteria used by the device for calculating the perceived temperature is the Humidex index.

7.11 Energy saving

In order to realise energy-saving functions, window contacts (to detect the opening of windows or doors), presence and movement sensors and card holders can be used.

The **Energy saving** folder includes the following secondary folders:

- Window contacts
- Presence sensors
- Card holder

7.11.1 Window contacts

The **Window contacts** secondary folder appears if at least a sensor dedicated to this function is enabled i.e. if at least one of the two conditions is verified:

- 1) Inputs \Rightarrow Input 1 and/or Input 2 = [DI] windows contact sensor
- 2) External sensors (from bus) \Rightarrow Windows contact sensor 1 or 2 (from bus) = enabled

For the function can be acquired up to four signals which are combined as a logic OR.

The **Window contacts** folder includes the following parameters:

- Window contacts function
- Wait time to building protection mode

7.11.1.1 Parameters and communication objects

Parameter name	Conditions	Values
Window contacts function		disabled / enabled
	<i>This parameter enables the window contact function.</i>	
Wait time to building protection mode	Window contacts function = enabled	00:01:00 hh:mm:ss [campo 00:00:00 ... 18:12:15]
	<i>Time interval before the automatic switching of the device to the Building protection operating mode.</i>	

Object name	Conditions	Dim.	Flags	DPT	Comm. Obj. No.
Window contact sensor (from input 1)	Window contacts function = enabled, Input 1 = [DI] windows contact sensor	1 Bit	CR-T-	[1.019] window/door	26
Window contact sensor (from input 2)	Window contacts function = enabled, Input 2 = [DI] windows contact sensor	1 Bit	CR-T-	[1.019] window/door	27
Windows contact sensor 1 (from bus)	Window contacts function = enabled, Window contact 1 = enabled	1 Bit	C-W--	[1.019] window/door	43

Object name	Conditions	Dim.	Flags	DPT	Comm. Obj. No.
Windows contact sensor 2 (from bus)	Window contacts function = enabled, Window contact 2 = enabled	1 Bit	C-W--	[1.019] window/door	44

7.11.2 Presence sensors

The **Presence sensors** folder includes the following parameters:

- Presence sensor function
- Presence sensors use
- Thermostat modes
- Absence time to switch HVAC mode

For this function only use external sensors (from bus) can be used, such as the ekinex EK-SM2-TP movement sensor or the ekinex EK-DX2-TP (X = B, C, D, E) presence sensor. The following condition has to be true:

External sensors (from bus) ⇒ Presence sensor 1 (from bus) or Presence sensor 2 (from bus) = enabled

7.11.2.1 Parameters and communication objects

Parameter name	Conditions	Values
Presence sensor function		disabled / enabled
	<i>Parameter that enables the presence sensor function.</i>	
Presence sensors use	Presence sensor function = enabled	comfort extension comfort limitation comfort extension and comfort limitation
Thermostat modes	Presence sensor function = enabled, Presence sensors use = comfort extension and comfort limitation or = comfort limitation	comfort-standby comfort-economy
Absence time to switch HVAC mode	Presence sensor function = enabled	00:01:00 hh:mm:ss [range 00:00:00 ... 18:12:15]
	<i>Time interval before the automatic switching of the operating mode set in the Thermostat modes parameter.</i>	

Object name	Conditions	Dim.	Flags	DPT	Comm. Obj. No.
Presence sensor 1 (from bus)	Presence sensor function = enabled	1 Bit	C-W---	[1.018] occupancy	32
Presence sensor 2 (from bus)	Presence sensor function = enabled	1 Bit	C-W---	[1.018] occupancy	33

7.11.3 Card holder

The **Card holder** secondary folder appears only if the corresponding sensor is enabled i.e. if one of the two mutually exclusive conditions is true:

- 1) Inputs ⇒ Input1 or Input 2 = [DI] card holder contact sensor or
- 2) External sensors (from bus) ⇒ Card holder contact = enabled

The **Card holder** folder includes the following parameters:

- Card holder function
- On card insertion switch HVAC mode to
- Activation delay on card insertion
- On card removal switch HVAC mode to
- Activation delay on card removal

7.11.3.1 Parameters and communication objects

Parameter name	Conditions	Values
Card holder function		disabled / enabled
<i>Parameter that enables the card holder function.</i>		
On card insertion switch HVAC mode to	Card holder function = enabled	none comfort standby economy
<i>This parameter defines to which operating mode the device should automatically switch inserting the card in the holder.</i>		
Activation delay on card insertion	Card holder function = enabled	00:00:00 hh:mm:ss [range 00:00:00 ... 18:12:15]
<i>Time interval before the automatic switching of the operating mode, inserting the card in the holder.</i>		
On card removal switch HVAC mode to	Card holder function = enabled	none standby economy building protection
<i>This parameter defines to which operating mode the device should automatically switch removing the card from the holder.</i>		
Activation delay on card removal	Card holder function = enabled	00:00:00 hh:mm:ss [range 00:00:00 ... 18:12:15]
<i>Time interval before the automatic switching of the operating mode, removing the card from the holder.</i>		

Object name	Conditions	Dim.	Flags	DPT	Comm. Obj. No.
Card holder contact sensor (from input 1)	Card holder function = enabled	1 Bit	CR-T--	[1.001] switch	30
Card holder contact sensor (from input 2)	Card holder function = enabled	1 Bit	CR-T--	[1.001] switch	31
Card holder contact sensor from bus	Card holder function = enabled	1 Bit	CR-T--	[1.001] switch	45

About the card holder function

The information of card insertion (removal) in (from) a card holder allows you to directly control the temperature by means of the room thermostat, while sending the object value on the bus allows you to control other room functions with KNX (lighting, electrical loads, feedback status for the hotel reception, etc.) depending on the configuration done with ETS. The value of the setpoint temperature and the switching have to be defined with the hotel responsible in accordance with the target of energy saving and level of service to be offered to the guests.

Conventional (not KNX) card holder

With a conventional card holder the status (card present or absent) of a signal contact is detected through an input of the device configured as *[DI] card holder contact sensor*. This way you can detect only the insertion and extraction of the card, but it cannot be detected e.g. the access of users with different profiles (guests, service staff, maintenance workforce).

KNX card holder

With a KNX card holder you can differentiate the switching to be carried out; this is not resolved by the parameters of the room temperature controller, but through the definition of scenes that are received by the device. Depending on the available device, advanced functions are possible (e.g. different user profiles).

7.12 Additional warnings

In addition to the alarms listed in Chapter 10. Diagnostics, up to four external warnings can be configured. They are displayed by the symbol "Alarm triangle" and a three-digit coding (F01 ... F04). It is advisable to report to the user about the meaning of the warning configured in the ETS project. These warnings do not block the regulating functions of the room temperature controller.

Differently from the alarms listed in Chapter 10. Diagnostics, managed automatically by the device, for these warnings there is no control by timeout and therefore you do not need to set a cyclical sending.

Object name	Conditions	Dim.	Flags	DPT	Comm. Obj. No.
Alarm 1 (from bus)	-	1 Bit	C-W---	[1.005] alarm	95
<i>It enables the configurable warning displayed by the symbol "Triangle alarm" and the code "F01".</i>					
Alarm 2 (from bus)	-	1 Bit	C-W---	[1.005] alarm	96
<i>It enables the configurable warning displayed by the symbol "Triangle alarm" and the code "F02".</i>					
Alarm 3 (from bus)	-	1 Bit	C-W---	[1.005] alarm	97
<i>It enables the configurable warning displayed by the symbol "Triangle alarm" and the code "F03".</i>					
Alarm 4 (from bus)	-	1 Bit	C-W---	[1.005] alarm	98
<i>It enables the configurable warning displayed by the symbol "Triangle alarm" and the code "F04".</i>					

7.13 Logic functions

The KNX room thermostat EK-EQ2-TP allows to use some useful logic functions (AND, OR, NOT and exclusive OR) in order to implement complex functions in the building automation system.

You can configure:

- 8 channels of logical functions
- 4 inputs for each channel

Each object value, if desired, can be individually inverted by inserting a NOT logic operator.

For each channel, a parameter *Delay after bus voltage recovery* is available: this parameter represents the time interval between the bus voltage recovery and the first reading of the input communication objects for evaluating the logic functions.



In case of uncorrect connection of the input communication object or electrical trouble on bus resulting in a failed input reading request, the logic output of the corresponding channel can be calculated by setting the input values to default.

The communication function representing the logic function output is sent on the bus on event of change; alternatively, a cyclic sending can be set.

7.13.1 Parameters and communication objects

The following condition has to be true: General \Rightarrow Logic functions = enabled.

Parameter name	Conditions	Values
Logic function		disabled / enabled
Logic operation	Logic function = enabled	OR / AND / XOR
	XOR (eXclusive OR)	
Delay after bus voltage recovery		00:00:04.000 hh:mm:ss.fff [range 00:00:00.000 ... 00:10:55.350]
	<i>Time interval between the bus voltage recovery and the first reading of the input communication objects for evaluating the logic functions</i>	
Output cyclic transmission delay		no sending [other value in range 30 s ... 120 min]
	<i>No sending means that the output state of the logic function is updated on the bus only on change. Different values imply cyclic sending on the bus of the output state.</i>	
Logic object x		disabled / enabled
Negated	Logic object x = enabled	no / yes
	<i>Negando lo stato logico dell'ingresso corrispondente, è possibile realizzare logiche combinatorie articolate. Esempio: Output=(NOT(Oggetto logico 1) OR Oggetto logico 2).</i>	
Read at startup	Logic object x = enabled	no / yes
Default value	Logic object x = enabled	none / off / on

<i>Object name</i>	<i>Conditions</i>	<i>Dim.</i>	<i>Flags</i>	<i>DPT</i>	<i>Comm. Obj. No.</i>
Logic function X – Input 1	Logic function X = enabled Logic object 1 = enabled	1 Bit	C-W--	[1.001] switch	104, 109, 114, 119, 124, 129, 134, 139
Logic function X – Input 2	Logic function X = enabled Logic object 2 = enabled	1 Bit	C-W--	[1.001] switch	105, 110, 115, 120, 125, 130, 135, 140
Logic function X – Input 3	Logic function X = enabled Logic object 3 = enabled	1 Bit	C-W--	[1.001] switch	106, 111, 116, 121, 126, 131, 136, 141
Logic function X – Input 4	Logic function X = enabled Logic object 4 = enabled	1 Bit	C-W--	[1.001] switch	107, 112, 117, 122, 127, 132, 137, 142
Logic function X – Output	Logic function X = enabled	1 Bit	C-W--	[1.001] switch	108, 113, 118, 123, 128, 133, 138, 143

8 List of communication objects

Nr.	Name	Size	Flags	Datapoint Type
0	Technical alarm	1 Bit	-WC---	[1.5] DPT_Alarm
2	Leds intensity percentage	1 Byte	-WC---	[5.1] DPT_Scaling
3	Temperature value	2 Bytes	R-CT--	[9.1] DPT_Value_Temp
6	Rocker 1 - Led first color A	1 Bit	RWCTU-	[1.1] DPT_Switch
7	Rocker 1 - Led second color A	1 Bit	RWCTU-	[1.1] DPT_Switch
8	Rocker 1 - Led first color B	1 Bit	RWCTU-	[1.1] DPT_Switch
9	Rocker 1 - Led second color B	1 Bit	RWCTU-	[1.1] DPT_Switch
10	Rocker 2 - Led first color A	1 Bit	RWCTU-	[1.1] DPT_Switch
11	Rocker 2 - Led second color A	1 Bit	RWCTU-	[1.1] DPT_Switch
12	Rocker 2 - Led first color B	1 Bit	RWCTU-	[1.1] DPT_Switch
13	Rocker 2 - Led second color B	1 Bit	RWCTU-	[1.1] DPT_Switch
14	Humidity value (1 byte)	1 Byte	R-CT--	[5.1] DPT_Scaling
15	Humidity value (2 bytes)	2 Bytes	R-CT--	[9.7] DPT_Value_Humidity
16	Temperature threshold 1 - Switch	1 Bit	R-CT--	[1.1] DPT_Switch
17	Temperature threshold 2 - Switch	1 Bit	R-CT--	[1.1] DPT_Switch
18	Humidity threshold 1 - Switch	1 Bit	R-CT--	[1.1] DPT_Switch
19	Humidity threshold 2 - Switch	1 Bit	R-CT--	[1.1] DPT_Switch
20	Coil battery temperature sensor (from input 1)	2 Bytes	R-CT--	[9.1] DPT_Value_Temp
20	Room temperature sensor (from input 1)	2 Bytes	R-CT--	[9.1] DPT_Value_Temp
20	Antistratification temperature sensor (from input 1)	2 Bytes	R-CT--	[9.1] DPT_Value_Temp
20	Floor surface temperature sensor (from input 1)	2 Bytes	R-CT--	[9.1] DPT_Value_Temp
20	Outdoor temperature sensor (from input 1)	2 Bytes	R-CT--	[9.1] DPT_Value_Temp
20	Temperature value sensor (from input 1)	2 Bytes	R-CT--	[9.1] DPT_Value_Temp
21	Temperature threshold 1 sensor 1 - Switch	1 Bit	R-CT--	[1.1] DPT_Switch
22	Temperature threshold 2 sensor 1 - Switch	1 Bit	R-CT--	[1.1] DPT_Switch
23	Coil battery temperature sensor (from input 2)	2 Bytes	R-CT--	[9.1] DPT_Value_Temp
23	Room temperature sensor (from input 2)	2 Bytes	R-CT--	[9.1] DPT_Value_Temp
23	Antistratification temperature sensor (from input 2)	2 Bytes	R-CT--	[9.1] DPT_Value_Temp
23	Floor surface temperature sensor (from input 2)	2 Bytes	R-CT--	[9.1] DPT_Value_Temp
23	Outdoor temperature sensor (from input 2)	2 Bytes	R-CT--	[9.1] DPT_Value_Temp
23	Temperature value sensor (from input 2)	2 Bytes	R-CT--	[9.1] DPT_Value_Temp
24	Temperature threshold 1 sensor 2 - Switch	1 Bit	R-CT--	[1.1] DPT_Switch
25	Temperature threshold 2 sensor 2 - Switch	1 Bit	R-CT--	[1.1] DPT_Switch
26	Window contact sensor (from input 1)	1 Bit	R-CT--	[1.19] DPT_Window_Door
27	Window contact sensor (from input 2)	1 Bit	R-CT--	[1.19] DPT_Window_Door
28	Anticondensation sensor (from input 1)	1 Bit	R-CT--	[1.5] DPT_Alarm
29	Anticondensation sensor (from input 2)	1 Bit	R-CT--	[1.5] DPT_Alarm
30	Card holder contact sensor (from input 1)	1 Bit	R-CT--	[1.18] DPT_Occupancy
31	Card holder contact sensor (from input 2)	1 Bit	R-CT--	[1.18] DPT_Occupancy
32	Presence sensor 1 (from bus)	1 Bit	-WC---	[1.18] DPT_Occupancy
33	Presence sensor 2 (from bus)	1 Bit	-WC---	[1.18] DPT_Occupancy

Nr.	Name	Size	Flags	Datapoint Type
34	Room temperature (from bus)	2 Bytes	-WC---	[9.1] DPT_Value_Temp
35	Humidity (2 bytes, from bus)	2 Bytes	-WC---	[9.7] DPT_Value_Humidity
36	Humidity (1 byte, from bus)	1 Byte	-WC---	[5.1] DPT_Scaling
37	Antistratification temperature (from bus)	2 Bytes	-WC---	[9.1] DPT_Value_Temp
38	Outdoor temperature (from bus)	2 Bytes	-WC---	[9.1] DPT_Value_Temp
39	Air quality (from bus)	2 Bytes	-WC---	[9.8] DPT_Value_AirQuality
40	Coil temperature (from bus)	2 Bytes	-WC---	[9.1] DPT_Value_Temp
41	Floor temperature (from bus)	2 Bytes	-WC---	[9.1] DPT_Value_Temp
42	Flow temperature (from bus)	2 Bytes	-WC---	[9.1] DPT_Value_Temp
43	Windows contact sensor 1 (from bus)	1 Bit	-WC---	[1.19] DPT_Window_Door
44	Windows contact sensor 2 (from bus)	1 Bit	-WC---	[1.19] DPT_Window_Door
45	Contact of card holder (from bus)	1 Bit	-WC---	[1.18] DPT_Occupancy
46	Anticondensation (from bus)	1 Bit	-WC---	[1.1] DPT_Switch
47	Weighted temperature	2 Bytes	R-CT--	[9.1] DPT_Value_Temp
48	Heating/cooling status out	1 Bit	R-CT--	[1.100] DPT_Heat_Cool
49	Heating/cooling status in	1 Bit	-WC---	[1.100] DPT_Heat_Cool
50	HVAC mode in	1 Byte	-WC---	[20.102] DPT_HVACMode
51	HVAC forced mode in	1 Byte	-WC---	[20.102] DPT_HVACMode
52	Actual setpoint	2 Bytes	R-CT--	[9.1] DPT_Value_Temp
53	HVAC manual mode	1 Byte	-WCTU-	[20.102] DPT_HVACMode
54	Chrono active status	1 Bit	R-CT--	[1.11] DPT_State
55	Manual setpoint	2 Byte	-WC---	[9.1] DPT_Value_Temp
56	Manual/forced setpoint active status	1 Bit	RWCTU-	[1.11] DPT_State
57	Comfort setpoint (heating)	2 Bytes	RWCTU-	[9.1] DPT_Value_Temp
58	Comfort setpoint (cooling)	2 Bytes	RWCTU-	[9.1] DPT_Value_Temp
59	Standby setpoint (heating)	2 Bytes	RWCTU-	[9.1] DPT_Value_Temp
60	Standby setpoint (cooling)	2 Bytes	RWCTU-	[9.1] DPT_Value_Temp
61	Economy setpoint (heating)	2 Bytes	RWCTU-	[9.1] DPT_Value_Temp
62	Economy setpoint (cooling)	2 Bytes	RWCTU-	[9.1] DPT_Value_Temp
63	Building protection setpoint (heating)	2 Bytes	RWCTU-	[9.1] DPT_Value_Temp
64	Building protection setpoint (cooling)	2 Bytes	RWCTU-	[9.1] DPT_Value_Temp
65	Heating out command	1 Byte	R-CT--	[5.1] DPT_Scaling
65	Heating out command	1 Bit	R-CT--	[1.1] DPT_Switch
65	Heating and cooling out command	1 Bit	R-CT--	[1.1] DPT_Switch
65	Heating and cooling out command	1 Byte	R-CT--	[5.1] DPT_Scaling
66	Cooling out command	1 Byte	R-CT--	[5.1] DPT_Scaling
66	Cooling out command	1 Bit	R-CT--	[1.1] DPT_Switch
67	Auxiliary heating output command	1 Bit	R-CT--	[1.1] DPT_Switch
67	Auxiliary heating and cooling output command	1 Bit	R-CT--	[1.1] DPT_Switch
68	Auxiliary cooling output command	1 Bit	R-CT--	[1.1] DPT_Switch
69	Auxiliary heating disable	1 Bit	-WC---	[1.3] DPT_Enable
70	Auxiliary cooling disable	1 Bit	-WC---	[1.3] DPT_Enable

Nr.	Name	Size	Flags	Datapoint Type
71	Fan continuous speed	1 Byte	R-CT--	[5.1] DPT_Scaling
72	Fan speed 1	1 Bit	R-CT--	[1.1] DPT_Switch
73	Fan speed 2	1 Bit	R-CT--	[1.1] DPT_Switch
74	Fan speed 3	1 Bit	R-CT--	[1.1] DPT_Switch
75	Fan control disable	1 Bit	-WC---	[1.2] DPT_Bool
76	Fan manual speed	1 Byte	RWCTU-	[5.10] DPT_Value_1_Ucount
77	Fan speed status	1 Byte	R-CT--	[5.10] DPT_Value_1_Ucount
78	Fan manual active status	1 Bit	RWCTU-	[1.11] DPT_State
79	HVAC scene number	1 Byte	-WC---	[17.1] DPT_SceneNumber [18.1] DPT_SceneControl
80	Comfort state	1 Bit	R-CT--	[1.6] DPT_BinaryValue
81	Dew-point temperature	2 Byte	R-CT--	[9.1] DPT_Value_Temp
82	Perceived temperature	2 Byte	R-CT--	[9.1] DPT_Value_Temp
83	HVAC mode out	1 Byte	R-CT--	[20.102] DPT_HVACMode
84	Dehumidification command	1 Bit	R-CT--	[1.1] DPT_Switch
85	Dehumidification control disable	1 Bit	-WC---	[1.3] DPT_Enable
86	Dehumidification water battery command	1 Bit	R-CT--	[1.1] DPT_Switch
87	Dehumidification integration control	1 Bit	R-CT--	[1.1] DPT_Switch
88	Humidification command	1 Bit	R-CT--	[1.1] DPT_Switch
89	Humidification control disable	1 Bit	-WC---	[1.3] DPT_Enable
90	Temperature setpoint change lock	1 Bit	-WC---	[1.3] DPT_Enable
91	Manual mode lock	1 Bit	-WC---	[1.3] DPT_Enable
92	Anticondensation alarm	1 Bit	R-CT--	[1.5] DPT_Alarm
93	Rockers lock	1 Bit	-WC---	[1.2] DPT_Bool
94	Thermal generator lock	1 Bit	-WC---	[1.5] DPT_Alarm
95	Alarm from bus 1	1 Bit	-WC---	[1.5] DPT_Alarm
96	Alarm from bus 2	1 Bit	-WC---	[1.5] DPT_Alarm
97	Alarm from bus 3	1 Bit	-WC---	[1.5] DPT_Alarm
98	Alarm from bus 4	1 Bit	-WC---	[1.5] DPT_Alarm
99	Relative humidity setpoint for dehumidification	2 Byte	RWCTU-	[9.7] DPT_Value_Humidity
100	Relative humidity setpoint for humidification	2 Byte	RWCTU-	[9.7] DPT_Value_Humidity
101	Building protection HVAC mode active	1 Bit	R-CT--	[1.11] DPT_State
102	Fan manual speed percentage	1 Byte	R-CT--	[5.1] DPT_Percentage
103	Fan manual speed off status	1 Bit	R-CT--	[1.11] DPT_State
104, 109, 114, 119, 124, 129, 134, 139	Logic Function X, Input 1	1 Bit	-WC---	[1.1] DPT_Switch
105, 110, 115, 120, 125, 130, 135, 140	Logic Function X, Input 2	1 Bit	-WC---	[1.1] DPT_Switch
106, 111, 116, 121, 126, 131, 136, 141	Logic Function X, Input 3	1 Bit	-WC---	[1.1] DPT_Switch
107, 112, 117, 122, 127, 132, 137, 142	Logic Function X, Input 4	1 Bit	-WC---	[1.1] DPT_Switch
108, 113, 118, 123, 128, 133, 138, 143	Logic Function X, Output	1 Bit	R-CT--	[1.1] DPT_Switch

9 Regulation algorithms

The picture below shows the components of a common generic control system for room temperature. The room temperature controller measures the actual temperature (T_{eff}) of the air mass and constantly compares it to the setpoint value (T_{set}).

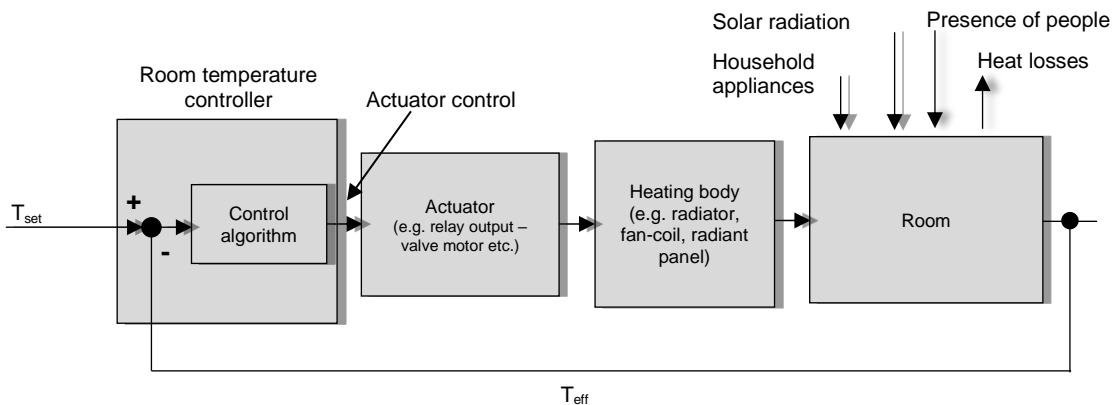

The control algorithm, basing on the difference between the setpoint (T_{set}) and the measured (T_{eff}) temperature values, processes a command value which can be a percentage or On / Off; the command is represented by a communication object that is transmitted via bus, either periodically or event based, to a KNX actuator device.

The output of the actuator device is the driving variable of the control system, which can be e.g. a flow rate of water or air. The control system realized by the room temperature controller is of feedback type (closed loop), namely the algorithm takes into account the effects on the system in order to change the control action on the same entity.

9.1.1.1 Two-point control with hysteresis

This control algorithm, which is also known as On / Off, is the most classic and popular. The control provides for the on / off switching of the system following a hysteresis loop, i.e. two threshold levels are considered for the switching (instead of a single one).

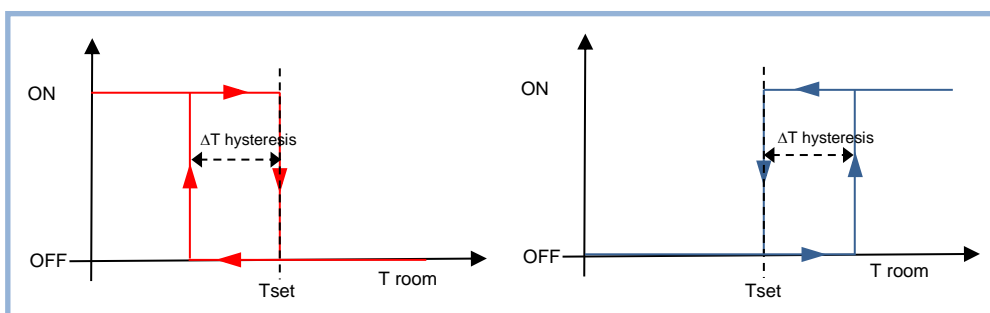

Heating mode – When the measured temperature is lower than the value of the difference ($T_{set} - \Delta T_{hysteresis}$), where $\Delta T_{hysteresis}$ identifies the differential adjustment of the heating, the device activates the heating system by sending a KNX telegram to the actuator that controls the heating system; when the measured temperature reaches the desired temperature (T_{set}), the device disables the heating system by sending a corresponding telegram. In this way, there are two decision thresholds for activation and deactivation of the

heating, the first one being the level ($T_{set} - \Delta T_{hysteresis}$), below which the device activates the system, whereas the second one is the desired temperature (T_{set}), above which the heating system is deactivated.

Cooling mode – When the measured temperature is higher than the value of the difference ($T_{set} + \Delta T_{hysteresis}$), where $\Delta T_{hysteresis}$ identifies the differential adjustment of the cooling, the device activates the cooling system by sending a KNX telegram to the actuator that controls the cooling system; when the measured temperature reaches the desired temperature (T_{set}), the device disables the cooling system by sending a corresponding telegram. In this way, there are two decision thresholds for activation and deactivation of the cooling, the first one being the level ($T_{set} + \Delta T_{hysteresis}$), above which the device activates the system, whereas the second one is the desired temperature (T_{set}), below which the cooling system is deactivated.

In the ETS application program, two different parameters are available for the hysteresis values for heating and cooling: the values usually differ depending on the system type and its inertia.

In the applications where underfloor or ceiling radiant panels are used, a different temperature control can be realised. This type of control must be combined with a system for regulating the supply water temperature that takes into account the internal conditions or to an optimizer that exploits the thermal capacity of the building to differ the energy inputs. In this kind of control the hysteresis ($\Delta T_{hysteresis}$) or the room temperature limit ($T_{set} + \Delta T_{hysteresis}$) represent the level of deviation from the desired condition that the user is willing to accept during the running of the system.

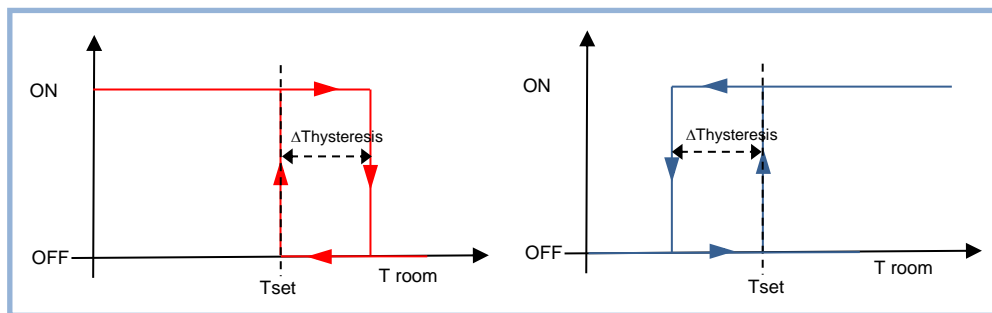

Heating mode – When the measured temperature is lower than the value T_{set} , the device activates the heating system by sending a KNX telegram to the actuator that controls the heating system; when the measured temperature reaches the desired temperature ($T_{set} + \Delta T_{hysteresis}$), where $\Delta T_{hysteresis}$ identifies the differential adjustment of the heating, the device disables the heating system by sending a corresponding telegram. In this way, there are two decision thresholds for activation and deactivation of the heating, the first one being the desired temperature T_{set} , below which the device activates the system, whereas the second one is the ($T_{set} + \Delta T_{hysteresis}$), above which the device deactivates the heating system.

Cooling mode – When the measured temperature is higher than the value T_{set} , the device activates the cooling system by sending a KNX telegram to the actuator that controls the cooling system; when the measured temperature reaches the value ($T_{set} - \Delta T_{hysteresis}$), where $\Delta T_{hysteresis}$ identifies the differential adjustment of the cooling, the device disables the cooling system by sending a corresponding telegram. In this way, there are two decision thresholds for activation and deactivation of the cooling, the first one being T_{set} , above which the device activates the system, whereas the second one is ($T_{set} - \Delta T_{hysteresis}$), below which the cooling system is deactivated.

In the application program the hysteresis values for heating and cooling are differentiated: for the detection of the correct values is necessary to consider the inertia characteristic of the system.

In the ETS application program the control algorithm with 2 points hysteresis proposed as default offers a *lower* hysteresis for heating and an *upper* hysteresis for cooling. If the parameter *Heating type* and / or

Cooling type = floor radiant panels or ceiling radiant panels it is possible to select the position of the hysteresis according to the second method described, i.e. with upper hysteresis for heating and lower hysteresis for cooling.

The desired temperature (T_{set}) is usually different for each of the four operating modes and for the two seasonal modes of the device. Values are defined for the first time during the configuration with ETS and can be changed later. To maximize energy savings (for every extra degree of temperature, heat loss to the outside and energy consumption increase of about 6%), you can easily take advantage of the multi-functionality of the home automation system, for example with:

- hourly programming with automatic switching of the operating mode by a KNX device with supervisor function;
- automatic switching of the operating mode depending on the presence of people in the room;
- automatic switching of the operating mode at the opening of windows for air circulation;
- stop of the circulating pump when thermostats are satisfied;
- reduction of the flow temperature in partial load conditions.

9.1.1.2 Continuous Proportional-Integral control

The Proportional-Integral control (PI) is described by the following relation:

$$\text{control variable}(t) = Kp \times \text{error}(t) + Ki \times \int_0^t \text{error}(\tau) d\tau$$

where:

$\text{error}(t) = (\text{Setpoint} - \text{Measured temperature})$ in heating

$\text{error}(t) = (\text{Measured temperature} - \text{Setpoint})$ in cooling

$Kp = \text{proportional constant}$

$Ki = \text{integral constant}$

The control variable is composed of a part that depends proportionally from the error and a part that depends on the integral of the error.

In practice derived values with a more intuitive meaning are used.

$$\text{Proportional band } BP [K] = \frac{100}{Kp} \quad \text{Integral time } Ti [min] = \frac{Kp}{Ki}$$

The proportional band is the error value which determines the maximum excursion output at 100%.

For example, a regulator with proportional band of 5 K provides a 100% control output when the Setpoint = 20°C and the measured temperature is $\leq 15^\circ\text{C}$ in heating; in the cooling conduction mode, it provides a 100% control output when the Setpoint = 24°C and the measured temperature is $\geq 29^\circ\text{C}$. As shown in the figure, a regulator with a small proportional band tends to provide higher values of the control variable for small errors than a regulator with a higher proportional band.

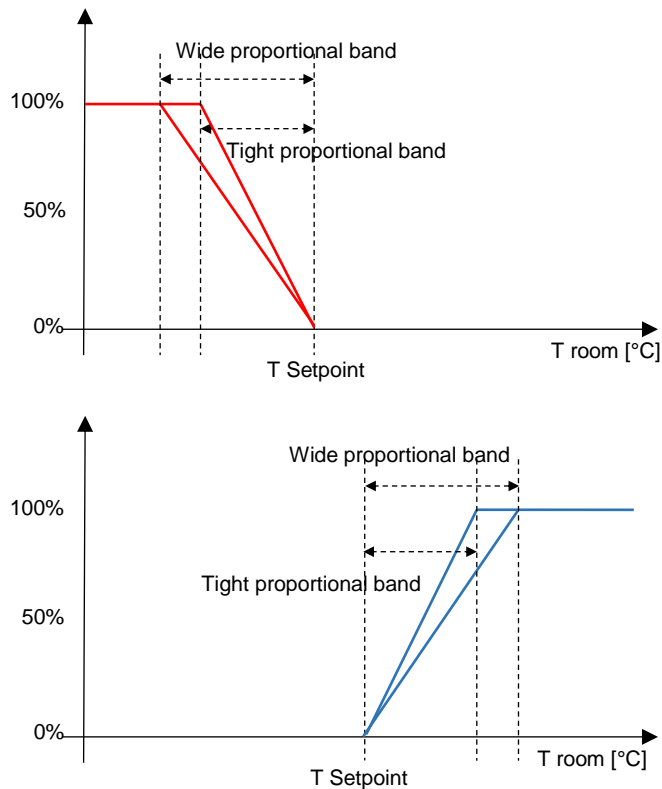

The integral time is the time required to repeat the value of the control variable of a purely proportional regulator, when the error remains constant in time.

For example, with a purely proportional controller in heating and with a value of proportional band of 4 K, if the setpoint is = 20°C and the measured temperature is = 18°C, the control variable assumes the value of 50%. With an integral time = 60 minutes, if the error remains constant, the control variable will take the value = 100% after 1 hour, i.e. a contribution equal to the value given by only proportional contribution will be added to the control variable.

In heating and air conditioning systems, a purely proportional controller is not able to guarantee the achievement of the setpoint. You should always introduce an integrated action for achieving the Setpoint: that is why the integral action is also called automatic reset.

9.1.1.3 PWM Proportional-Integral control

The PWM (Pulse Width Modulator) proportional-integral controller uses an analog control variable to modulate the duration of the time intervals in which a binary output is in the ON or OFF state. The controller operates in a periodic manner over a cycle, and in each period it maintains the output to the ON value for a time proportional to the value of the control variable. As shown in the figure, by varying the ratio between the ON time and the OFF time, the average time of activation of the output varies, and consequently the average heating or cooling power supplied to the room.

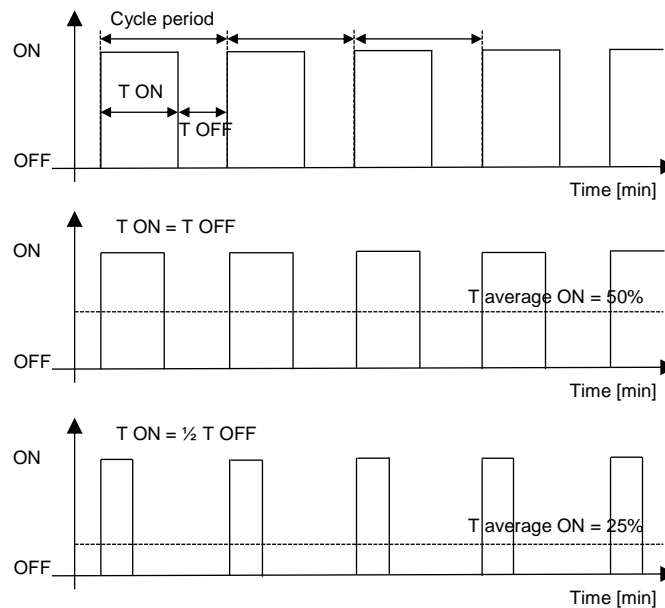

This type of control is well suited for use with ON / OFF actuators, such as electrothermal actuators and drives for zone valves, which are less expensive than proportional actuators.

A distinctive advantage of this type of control is that it eliminates the inertia of the system: it allows significant energy savings, because unnecessary interventions on the system introduced by the 2-point control with hysteresis are avoided and only the power required to compensate the losses of the building is supplied.

Every time the user or the supervisor changes the desired temperature setpoint, the cycle time is interrupted, the control output is reprocessed and the PWM restarts with a new cycle: this allows the system to reach its steady state more quickly.

System terminals	Proportional band [K]	Integral time [min]	Cycle time [min]
Radiators	5	150	15-20
Electrical heaters	4	100	15-20
Fan-coils	4	90	15-20
Underfloor radiant panels	5	240	15-20

The following are guidelines for the choice of parameters for a proportional-integral PWM control.

- Cycle time: for low inertia systems, such as air heating and conditioning systems, short periods (10-15 minutes) have to be chosen, in order to avoid temperature fluctuations.
- Tight proportional band: large and continuous fluctuations of the room temperature, short settling time to the setpoint.
- Wide proportional band: small fluctuations or absence of fluctuations of the room temperature, long settling time to the setpoint
- Short integral time: short settling time to the setpoint, continuous fluctuations of the room temperature around the setpoint
- Long integral time: long settling time to the setpoint, absence of temperature fluctuations

9.1.1.4 Fan-coil with ON-OFF fan speed control

This type of fan-coil control is similar to the 2 points control with hysteresis analyzed in the previous section: the fan speed is activated / deactivated according to the difference between the desired temperature (T_{set}) and the measured temperature (T_{room}). The relevant difference with the 2 points algorithm with hysteresis is that, in this case, there is not a single stage on which the hysteresis loop is executed, by setting the thresholds for switching on and off of the speed, but three stages may exist (depending on the speed levels of the fan-coil). This means that a speed level corresponds to each stage and when the difference between the measured temperature and the desired temperature causes the activation of a further speed, before activating the new speed, the other two must be turned off to avoid any damage to the fan motor.

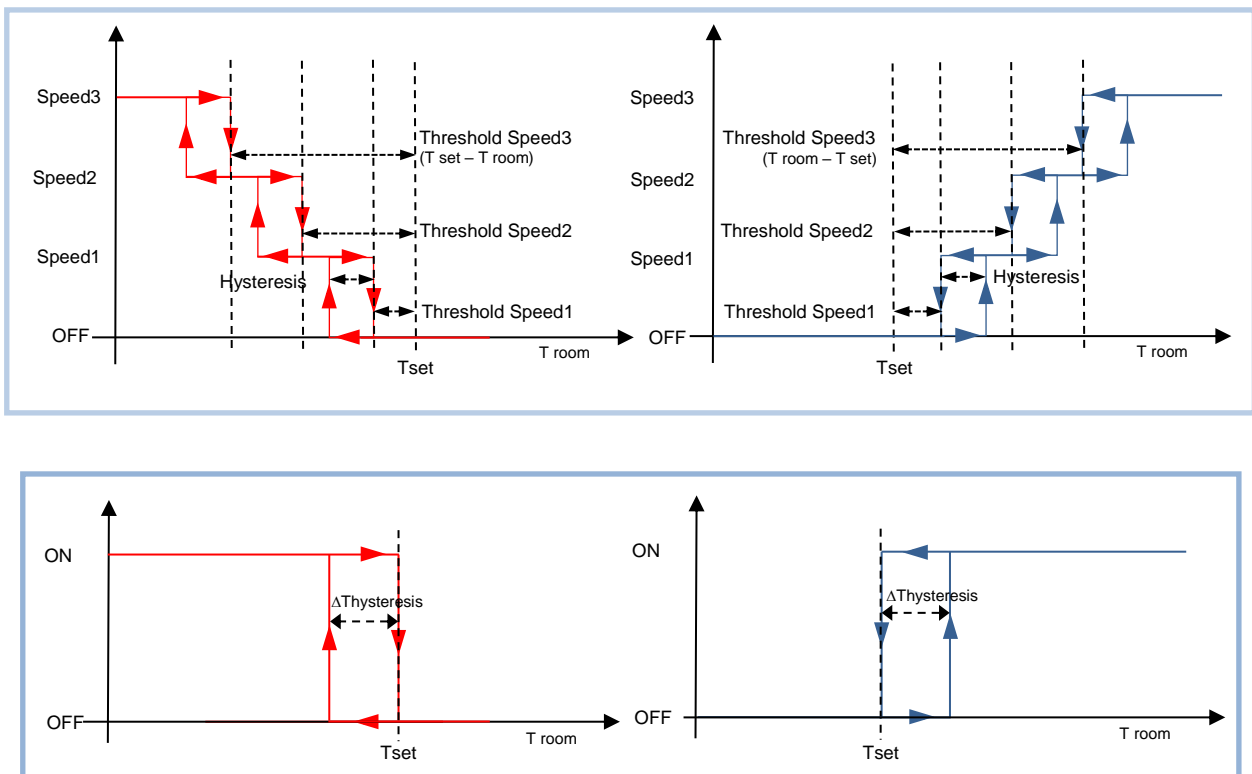

The figure in the upper left graph refers to the speed control of the fan-coil with three operating stages as regards the heating. Looking at the graph, it has to be noted that for each stage there is a hysteresis loop, as well as at any speed are assigned two thresholds which determine the activation and deactivation. The thresholds are determined by the values set in the application program and can be summarized as follows:

- Speed 1 (1st stage) – The speed is turned ON when the value of the room temperature is lower than the value ($T_{Set} - \text{Threshold Speed1} - \text{hysteresis}$) and turned OFF when the room temperature value reaches the value ($T_{Set} - \text{Threshold Speed1}$); the first speed is also switched OFF when a higher speed must be turned ON. The default value for the parameter Threshold Speed1 = 0 K
- Speed 2 (2nd stage) – The speed is turned ON when the value of the room temperature is lower than the value ($T_{Set} - \text{Threshold Speed2} - \text{hysteresis}$) and turned OFF when the room temperature value reaches the value ($T_{Set} - \text{Threshold Speed2}$); the second speed is also switched OFF when Speed3 must be turned ON.
- Speed 3 (3rd stage) – The speed is turned ON when the value of the room temperature is lower than the value ($T_{Set} - \text{Threshold Speed3} - \text{hysteresis}$) and turned OFF when the room temperature value reaches the value ($T_{Set} - \text{Threshold Speed3}$)

The parameter of the application program ETS *Speed control hysteresis* represents the hysteresis value shared by all the speed stages and unified for heating and cooling.

As regards the shut-off valve of the water coil (2 pipe configuration) or the shut-off valve of the water battery for heating (4 pipe system), it can be used an algorithm with 2 points hysteresis that works with the same setpoint values in the application program. If the room temperature is lower than the value ($T_{Set} - \Delta T_{hysteresis}$), the device sends the activation command of the valve; the shut-off valve is turned off, however, when the room temperature reaches the T_{Set} value and deactivates at the same time also the speed 1 of the fan. In this way it is also avoided the formation of "puffs" on the walls due to the circulation of water in the battery without convective heat transfer.

The figure in the in the upper right graph refers to the speed control of the fan-coil with three operating stages as regards the cooling. Looking at the graph, it has to be noted that for each stage there is a hysteresis loop, as well as at any speed are assigned two thresholds which determine the activation and deactivation. The thresholds are determined by the values set in the application program and can be summarized as follows:

- Speed 1 (1st stage) – The speed is turned ON when the value of the room temperature is higher than the value ($T_{Set} + \text{Threshold Speed1} + \text{hysteresis}$) and turned OFF when the room temperature value reaches the value ($T_{Set} + \text{Threshold Speed1}$); the first speed is also switched OFF when a higher speed must be turned ON. The default value for the parameter *Threshold Speed1* = 0 K
- Speed 2 (2nd stage) – The speed is turned ON when the value of the room temperature is higher than the value ($T_{Set} + \text{Threshold Speed2} + \text{hysteresis}$) and turned OFF when the room temperature value reaches the value ($T_{Set} + \text{Threshold Speed2}$); the second speed is also switched OFF when Speed3 must be turned ON.
- Speed 3 (3rd stage) – The speed is turned ON when the value of the room temperature is higher than the value ($T_{Set} + \text{Threshold Speed3} + \text{hysteresis}$) and turned OFF when the room temperature value reaches the value ($T_{Set} + \text{Threshold Speed3}$)

As regards the shut-off valve of the water coil (2 pipe configuration) or the shut-off valve of the water battery for heating (4 pipe system), it can be used an algorithm with 2 points hysteresis that works with the same setpoint values in the application program. If the room temperature is higher than the value ($T_{Set} + \Delta T_{hysteresis}$), the device sends the activation command of the valve; the shut-off valve is turned off, however, when the room temperature reaches the T_{Set} value and deactivates at the same time also the speed 1 of the fan.

Both figures make reference to the control of the 3-speed fan-coil, explanations are in this case exhaustive and, for cases 2 or single-stage, the operation is the same with the only difference that not all the speed will be controlled.

It must be noted that in applications for fan-coil in which both heating and cooling are active, the speed thresholds are the same in the two conduction modes of the system.

To coordinate the action of the fan with the shut-off valve of the heat exchanger, it is necessary to pay attention to the values of hysteresis chosen: for example, selecting in the folder *Ventilation* the parameters *Threshold first speed* = 0 K and *Hysteresis speed control* = 0,3 K, in the folders *Heating* and / or *Cooling* the parameter *Hysteresis* = 0,3 K, to ensure that when speed 1 is turned ON, the valve on the exchange battery is open.

A further element of flexibility is offered by the possibility of subordinating the manual operation of the ventilation to the achievement of the desired temperature T_{Set} . Selecting in the ETS *Ventilation* folder the parameter *Manual operation = temperature independent*, the ventilation will continue to operate at the speed set by the user, also when the desired temperature is achieved; vice versa with the setting in ETS *Manual*

Operation = temperature dependent the ventilation handled manually by the user will be anyway interrupted when the desired conditions are achieved.

The communication between the controller and the actuator can be made indifferently either via the communication objects of type [1.1] DPT_Switch (168-169-170, Speed 1-2-3 fan) or a single object [5.1] DPT_Scaling (167 speed continuous fan). It should be highlighted that the object (167, continuous fan speed), with ON / OFF speed control, does not vary in a continuous manner but assumes only discrete values, respecting the hysteresis of the ON / OFF windows defined by the thresholds, according to the following table.

Fan speed in automatic	Communication objects fan speed, [1.1] DPT_Switch			Communication objects continuous fan speed, [5.1] DPT_Scaling
	V1	V2	V3	
<i>Control type: 3 speed</i>				
OFF	0	0	0	0 %
1	1	0	0	33,3 %
2	0	1	0	66,7 %
3	0	0	1	100 %
<i>Control type: 2 speed</i>				
OFF	0	0	-	0 %
1	1	0	-	50 %
2	0	1	-	100 %
<i>Control type: 1 speed</i>				
OFF	0	-	-	0 %
1	1	-	-	100 %

During the changeover, before activating the new speed value, the other ones must be disabled to prevent damage to the drive of the fan: all the communication objects both binary and continuous are therefore updated to the OFF (0%) value, before being updated to the next speed value by the internal regulator.

9.1.1.5 Fan-coil with continuous speed control

In this type of control independent 1 Bit communication objects are not used. A single 1 Byte (DPT 5.001 percentage) communication object is used: this implies that, before activating a speed value, it is not necessary to disable the other ones.

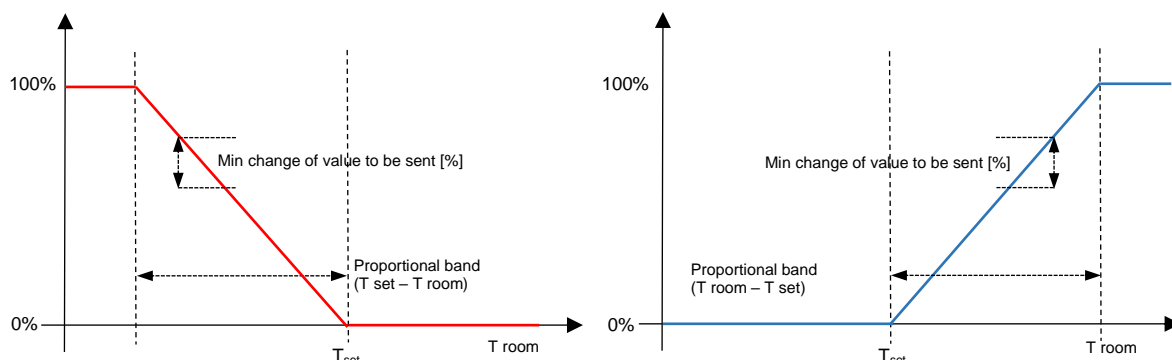

The definition of the hysteresis levels must be carried out directly on the actuator device of the fan-coil. The application program provides the *Proportional Band* parameter that assumes the same value both for heating and cooling: this parameter determines the slope of intervention of the fan. The *Minimum change value to send [%]* parameter is defined in order to limit the telegram traffic on the bus.

i

The *Continuous speed fan (167)* communication object, with 1 Byte size, varies in a continuous way according to the characteristic illustrated in the figure. See also the previous section to evaluate differences with the 1-2-3 fan speed mode, in which instead the same communication object assumes discrete values.

9.1.1.6 2 points control with hysteresis for auxiliary stage

The systems for heating and cooling have different values of inertia depending on the type of transfer of thermal energy. To shorten the time necessary to reach the comfort conditions, a low inertia heating / cooling system may be used, supporting the main system when in the starting phase the difference between the setpoint temperature (T_{set}) and the measured temperature (T_{room}) is accentuated.

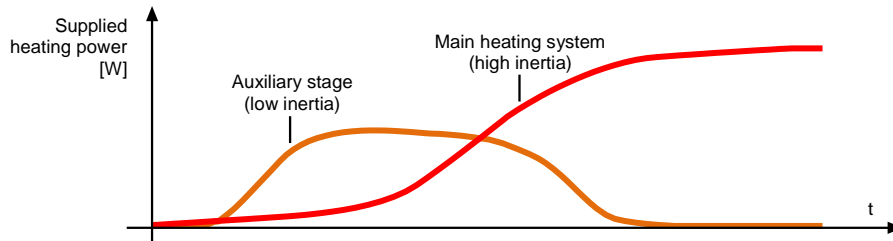

The system, defined as second stage or auxiliary stage, contributes in the early phase to heat up / cool down the room, then stops its action when the difference between T_{set} and T_{room} can be addressed satisfactorily by the main system only. The auxiliary stage is operated generally by a 2 points control algorithm with hysteresis.

Heating conduction mode

When the measured temperature (T_{room}) is lower than the value ($T_{set} - \Delta T_{Offset} - \Delta T_{hysteresis}$), where $\Delta T_{hysteresis}$ identifies the differential heating control, the device activates the auxiliary heating stage by sending a corresponding telegram to the dedicated actuator; when the measured temperature reaches the value ($T_{set} - \Delta T_{Offset}$) the device disables the auxiliary heating system by sending a corresponding telegram to the actuator.

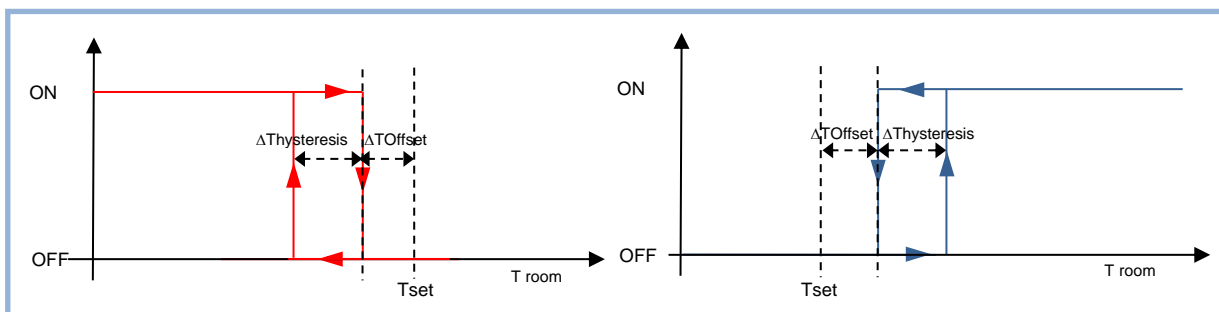

Cooling conduction mode

When the measured temperature (T_{room}) is higher than the value ($T_{set} + \Delta T_{Offset} + \Delta T_{hysteresis}$), where $\Delta T_{hysteresis}$ identifies the differential cooling control, the device activates the auxiliary cooling stage by sending a corresponding telegram to the dedicated actuator; when the measured temperature reaches the value ($T_{set} + \Delta T_{Offset}$) the device disables the auxiliary cooling system by sending a corresponding telegram to the actuator.

9.1.1.7 Auxiliary stage with fan-coil

An interesting system solution combines an underfloor radiant panel, a high inertia system acting on the masses of the structure, with an auxiliary fan-coil stage that acts instead on the air volumes: the room temperature controller EK-EP2-TP and EK-EF2-TP can be easily configured for this type of application.

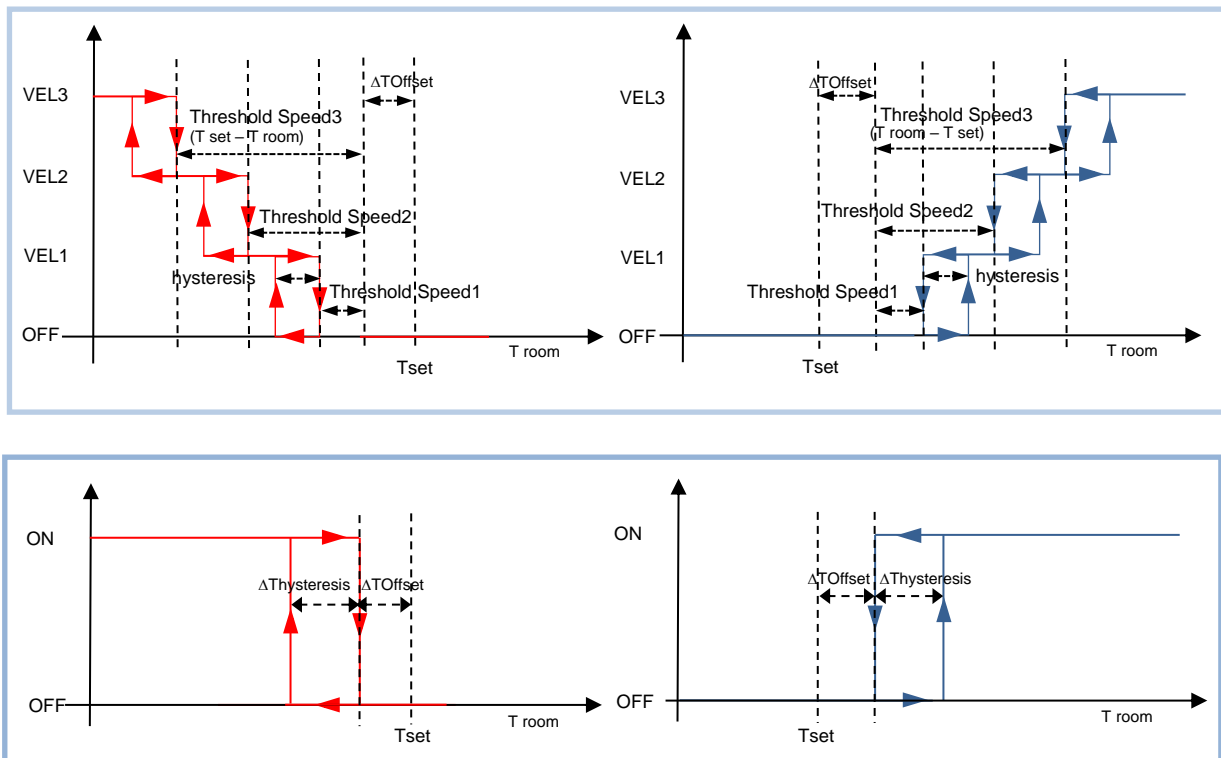

With regard to the configuration of the auxiliary stage, the same considerations expressed in the paragraph concerning fan-coil control with ON / OFF or continuous speed control are valid. The offset of the secondary stage, ΔT_{Offset} , is particularly important and it corresponds to the parameter *Heating and / or cooling deviation from setpoint*. By configuring *Deviation from the set point* (which can be differentiated between heating and cooling if the communication objects for control are separated) = 0 K, the radiant panel and the fan-coil function as two heating and / or cooling elements in parallel. If that parameter deviation from the setpoint is > 0 K, the fan-coil intervenes quickly in the early stages of the set up of the room, leaving the radiant panel the task of bringing the room to the desired temperature.

10 Diagnostics

Alarm code	Cause
A01	Surface temperature limit is exceeded
A02	Formation of condensation
A03	Thermal generator lock
F01	Alarm 1 (from bus)
F02	Alarm 2 (from bus)
F03	Alarm 3 (from bus)
F04	Alarm 4 (from bus)
Error code	Cause
E00	Integrated temperature sensor fault
E01	Integrated relative humidity sensor fault
E06	Analogic input 1: NTC sensor fault
E07	Analogic input 1: room temperature sensor fault
E08	Analogic input 1: fan-coil temperature sensor fault
E09	Analogic input 1: surface temperature sensor fault
E10	Analogic input 1: external temperature sensor fault
E14	Analogic input 2: NTC sensor fault
E15	Analogic input 2: room temperature sensor fault
E16	Analogic input 2: fan-coil temperature sensor fault
E17	Analogic input 2: surface temperature sensor fault
E18	Analogic input 2: external temperature sensor fault
E22	CO: quality air sensor fault
E23	CO: external temperature sensor fault
E24	CO: room temperature sensor fault
E25	CO: fan-coil temperature sensor fault
E26	CO: surface temperature sensor fault
E27	CO: flow temperature sensor fault
E28	CO: relative humidity sensor fault
E29	CO: antistratification temperature sensor fault
E33	CO: quality air sensor timeout
E34	CO: external temperature sensor timeout
E35	CO: room temperature sensor timeout
E36	CO: fan-coil temperature sensor timeout
E37	CO: surface temperature sensor timeout
E38	CO: flow temperature sensor timeout
E39	CO: relative humidity sensor timeout
E40	CO: antistratification temperature sensor timeout
E44	CO: anticondensation sensor timeout
E45	CO: window contact 1 timeout
E46	CO: window contact 2 timeout
E47	CO: presence sensor 1 timeout
E48	CO: presence sensor 2 timeout
E49	CO: card holder contact timeout

Table of alarm and error displayable codes.

Alarms F01 ... F04 are activated by communication objects; as they do not have any predefined meaning, they must be described by the system integrator in the project documentation.

11 Warnings

- Installation, electrical connection, configuration and commissioning of the device can only be carried out by qualified personnel in compliance with the applicable technical standards and laws of the respective countries
- Opening the housing of the device causes the immediate end of the warranty period
- In case of tampering, the compliance with the essential requirements of the applicable directives, for which the device has been certified, is no longer guaranteed
- ekinex® KNX defective devices must be returned to the manufacturer at the following address: Ekinex S.p.A. Via Novara, 37 I-28010 Vaprio d'Agogna (NO) Italy

12 Other information

- The instruction sheet must be delivered to the end customer with the project documentation
- For further information on the product, please contact the ekinex® technical support at the e-mail address: support@ekinex.com or visit the website www.ekinex.com
- Each ekinex® device has a unique serial number on the label. The serial number can be used by installers or system integrators for documentation purposes and has to be added in each communication addressed to the ekinex® technical support in case of malfunctioning of the device
- ekinex® is a registered trademark of Ekinex S.p.A.
- KNX® and ETS® are registered trademarks of KNX Association cvba, Brussels

© Ekinex S.p.A. 2022. The company reserves the right to make changes to this documentation without notice.